

SECURE-TEMP® ASHT

Factory-built CHIMNEY
5", 6", 7", 8" & 10" dia.
TYPE HT

CONTENTS

LISTING LABELS AND WARNING LABEL ETCS277 (ASHT).....2-3	8- INTERIOR STRAIGHT INSTALLATION -SINGLE FLOOR (CANADA).....26-27
RECOMMENDATION & APPLICATIONS.....4-5	9- INTERIOR STRAIGHT INSTALLATION -MULTIPLE FLOOR (CANADA).....28-29
MAINTENANCE AND SIZING CHART.....6-7	10- INTERIOR INSTALLATION WITH CATHEDRAL CEILING (CANADA)....30-32
1- GENERAL INSTALLATION NOTES (USA).....8-9	11- OFFSET DEVIATION (CANADA).....33-36
2- INTERIOR STRAIGHT INSTALLATION -SINGLE FLOOR (USA).....10-11	12- EXTERIOR INSTALLATION (CANADA).....37-40
3-INTERIOR STRAIGHT INSTALLATION -MULTIPLE FLOOR (USA).....12-13	13- INTERIOR INSTALLATION ON A FURNACE, BOILER, OR WATER HEATER (USA & CANADA).....41-42
4-INTERIOR INSTALLATION WITH CATHEDRAL CEILING (USA).....14-16	14- SPECIALIZED COMPONENTS (USA & CANADA).....43
5-OFFSET DEVIATION (USA).....17-19	15- REPLACEMENT PARTS.....44-46
6-EXTERIOR INSTALLATION (USA)...20-23	
7- GENERAL INSTALLATION NOTES (CANADA).....24-25	

INSTALLATION

AND

OPERATION

INSTRUCTIONS

WARNING
A MAJOR CAUSE OF CHIMNEY-RELATED FIRES IS FAILURE TO MAINTAIN REQUIRED CLEARANCES (AIR SPACES) TO COMBUSTIBLE MATERIALS. IT IS OF UTMOST IMPORTANCE THAT THIS CHIMNEY BE INSTALLED ONLY IN ACCORDANCE WITH THESE INSTRUCTIONS.

Read these instructions and keep them for future reference

These instructions must be followed in all details. Failure to do so may result in a hazardous installation.

Listed: ETL 4002244
Standard: UL-103 TYPE HT
CAN / ULC-604
CAN / ULC-629
(6", 7", 8" only)



2125 Monterey, Laval, Quebec
Canada, H7L 3T6
800-667-3387

LISTING LABELS AND WARNING LABEL

ASHT - 6", 7", 8"

CERTIFIED TO / CERTIFIÉ UL-103 TYPE HT, CAN/ULC 629, CAN/ULC 604		
FACTORY-BUILT CHIMNEYS	CHEMINÉES PRÉFABRIQUÉES	
REFER TO INTERTEK'S DIRECTORY OF BUILDING PRODUCTS (https://bpdirectory.intertek.com) FOR DETAILED INFORMATION. MINIMUM CLEARANCE TO COMBUSTIBLES: 2 IN. (50mm) AIR SPACE TO COMBUSTIBLE MATERIALS AND BUILDING INSULATION OR AS ESTABLISHED BY FACTORY FURNISHED FIRESTOP SPACERS AND SUPPORT ASSEMBLY. SUITABLE FOR INTERIOR OR EXTERIOR INSTALLATION THIS CHIMNEY IS TO BE INSTALLED IN ACCORDANCE WITH SECURITY CHIMNEYS INTL.'S INSTALLATION INSTRUCTIONS.	SE RÉFÉRER AU RÉPERTOIRE D'INTERTEK (https://bpdirectory.intertek.com) POUR PLUS D'INFORMATION. ESPACE LIBRE MINIMAL AUX MATÉRIEAUX COMBUSTIBLES: ESPACE LIBRE DE 2 PO. (50mm) AUX MATIÈRES COMBUSTIBLES ET À L'ISOLATION DE LA BÂTISSSE OU TEL QU'ÉTABLI PAR LES COUPE-FEU ET SUPPORTS FOURNIS PAR LE FABRICANT. CONVIENT À UNE UTILISATION À L'EXTÉRIEUR OU À L'INTÉRIEUR CETTE CHEMINÉE DOIT ÊTRE INSTALLÉE CONFORMÉMENT AUX MANUEL D'INSTALLATION DE CHEMINÉES SÉCURITÉ INTL.	
CANADIAN APPLICATION: - CERTIFIED TO CANULC 629 FOR CONNECTION TO SOLID, LIQUID OR GAS FIRED APPLIANCES NORMALLY PRODUCING FLUE GASES OF 650°C (1200°F) OR LESS. NOTE: ON WOOD/COAL BURNING APPLIANCE INSTALLATION, PREMIUM SHIELDS ARE REQUIRED AROUND THE CHIMNEY FOR INTERIOR COMPLETELY ENCLOSED INSTALLATION EXCEPT ON LISTED FACTORY BUILT FIREPLACES WHEN IT IS CERTIFIED WITH IT AND IDENTIFIED AS SUCH ON THE FIREPLACE LABEL. - CERTIFIED TO CANULC 604 FOR CONNECTION TO LIQUID OR GAS FIRED APPLIANCES NORMALLY PRODUCING FLUE GASES OF 540°C (1004°F) OR LESS. USA APPLICATION: - CERTIFIED TO UL 103 TYPE HT RESIDENTIAL TYPE AND BUILDING HEATING APPLIANCE CHIMNEY PART.	APPLICATION CANADIENNE: - CERTIFIÉ CANULC 629 POUR RACCORDEMENT AUX APPAREILS UTILISANT DES COMBUSTIBLES SOLIDES, LIQUIDES OU GAZEUX DÉGAGEANT NORMALEMENT 650°C (1200°F) OU MOINS. NOTE: LE RACCORDEMENT SUR UN APPAREIL À COMBUSTIBLES SOLIDES REQUIERT L'UTILISATION DES COMPOSANTES COUPE RADIATION PREMIUM AUTOUR DE LA CHEMINÉE SI LA CHEMINÉE EST INSTALLÉE À L'INTÉRIEUR. COMPLÈTEMENT ENCLOSENNÉ, SAUF DANS LE CAS D'UN FOYER PRÉFABRIQUÉ HOMOLOGUÉ AVEC CE CONDUIT ET IDENTIFIÉ COMME TEL SUR SON ÉTIQUETTE D'HOMOLOGATION. - CERTIFIÉ CANULC 604 POUR RACCORDEMENT AUX APPAREILS UTILISANT DES COMBUSTIBLES LIQUIDES OU GAZEUX DÉGAGEANT NORMALEMENT 540°C (1004°F) OU MOINS. APPLICATION AMÉRICAINE: - CERTIFIÉ UL 103 TYPE HT PIÈCE DE CHEMINÉE POUR APPAREIL DE CHAUFFAGE RÉSIDENTIEL ET COMMERCIAL.	
MODEL - ASHT 6", 7", 8" - MODÈLE		code barre
ENGLISH DESCRIPTION xxxxxxxxxxxxxx FRENCH DESCRIPTION xxxxxxxxxxxxxx PRODUCT CODEXXXXXX smart code xxxxxxx		
MM/DD/AAAA Work order		LV MADE IN / FABRIQUÉ AU CANADA NP188 REV. 14

G-ASHT 6", 7", 8"

CERTIFIED TO / CERTIFIÉ UL-103 TYPE HT		
FACTORY-BUILT CHIMNEYS	CHEMINÉE PRÉFABRIQUÉES	
REFER TO INTERTEK'S DIRECTORY OF BUILDING PRODUCTS (https://bpdirectory.intertek.com) FOR DETAILED INFORMATION. MINIMUM CLEARANCE TO COMBUSTIBLES: 2 IN. (50mm) AIR SPACE TO COMBUSTIBLE MATERIALS AND BUILDING INSULATION OR AS ESTABLISHED BY FACTORY FURNISHED FIRESTOP SPACERS AND SUPPORT ASSEMBLY. SUITABLE FOR INTERIOR OR EXTERIOR INSTALLATION THIS CHIMNEY IS TO BE INSTALLED IN ACCORDANCE WITH SECURITY CHIMNEYS INTL.'S INSTALLATION INSTRUCTIONS.	SE RÉFÉRER AU RÉPERTOIRE D'INTERTEK (https://bpdirectory.intertek.com) POUR PLUS D'INFORMATION. ESPACE LIBRE MINIMAL AUX MATÉRIEAUX COMBUSTIBLES: ESPACE LIBRE DE 2 PO. (50mm) AUX MATIÈRES COMBUSTIBLES ET À L'ISOLATION DE LA BÂTISSSE OU TEL QU'ÉTABLI PAR LES COUPE-FEU ET SUPPORTS FOURNIS PAR LE FABRICANT. CONVIENT À UNE UTILISATION À L'EXTÉRIEUR OU À L'INTÉRIEUR CETTE CHEMINÉE DOIT ÊTRE INSTALLÉE CONFORMÉMENT AUX MANUEL D'INSTALLATION DE CHEMINÉES SÉCURITÉ INTL.	
USA APPLICATION: CERTIFIED TO UL 103 TYPE HT RESIDENTIAL TYPE AND BUILDING HEATING APPLIANCE CHIMNEY PART.	APPLICATION AMÉRICAINE: CERTIFIÉ UL 103 TYPE HT PIÈCE DE CHEMINÉE POUR APPAREIL DE CHAUFFAGE RÉSIDENTIEL ET COMMERCIAL.	
MODEL - ASHT G (6", 7", 8") - MODÈLE		code barre
ENGLISH DESCRIPTION xxxxxxxxxxxxxx FRENCH DESCRIPTION xxxxxxxxxxxxxx PRODUCT CODEXXXXXX smart code xxxxxxx		
MM/DD/AAAA Work order		LV MADE IN / FABRIQUÉ AU CANADA NP253 REV. 08

ASHT 6", 7", 8" - Accessory

CERTIFIED TO / CERTIFIÉ UL-103 TYPE HT, CAN/ULC 629, CAN/ULC 604		
ACCESSORIES FACTORY-BUILT CHIMNEYS	ACCESSOIRES CHEMINÉES PRÉFABRIQUÉES	
THIS CHIMNEY IS TO BE INSTALLED IN ACCORDANCE WITH MANUFACTURER'S INSTALLATION INSTRUCTIONS. REFER TO INTERTEK'S DIRECTORY OF BUILDING PRODUCTS (https://bpdirectory.intertek.com) FOR DETAILED INFORMATION. NOTE: ON WOOD/COAL BURNING APPLIANCE INSTALLATION, PREMIUM THIRD SHIELDS ARE REQUIRED AROUND THE CHIMNEY FOR INTERIOR COMPLETELY ENCLOSED INSTALLATION EXCEPT ON LISTED FACTORY BUILT FIREPLACES WHEN IT IS CERTIFIED WITH IT AND IDENTIFIED AS SUCH ON THE FIREPLACE LABEL.	CETTE CHEMINÉE DOIT ÊTRE INSTALLÉE CONFORMÉMENT AU MANUEL D'INSTALLATION DU FABRICANT. SE RÉFÉRER AU RÉPERTOIRE D'INTERTEK (https://bpdirectory.intertek.com) POUR PLUS D'INFORMATION. NOTE: LE RACCORDEMENT SUR UN APPAREIL À COMBUSTIBLES SOLIDES REQUIERT L'UTILISATION DES COMPOSANTES COUPE RADIATION PREMIUM AUTOUR DE LA CHEMINÉE SI LA CHEMINÉE EST INSTALLÉE À L'INTÉRIEUR COMPLÈTEMENT ENCLOSENNÉ, SAUF DANS LE CAS D'UN FOYER PRÉFABRIQUÉ HOMOLOGUÉ AVEC CE CONDUIT ET IDENTIFIÉ SUR L'ÉTIQUETTE D'HOMOLOGATION DU FOYER.	code barre
MODEL - ASHT 6", 7", 8" - MODÈLE		
ENGLISH DESCRIPTION xxxxxxxxxxxxxx FRENCH DESCRIPTION xxxxxxxxxxxxxx PRODUCT CODEXXXXXX smart code xxxxxxx		
MM/DD/AAAA Work order		LV MADE IN / FABRIQUÉ AU CANADA NP190 REV. 11

ASHT 6", 7", 8" - PREMIUM Accessory



CERTIFIED TO / CERTIFIÉ UL-103 TYPE HT, CAN/ULC 629, CAN/ULC 604		
ACCESSORIES FACTORY-BUILT CHIMNEYS	ACCESSOIRES CHEMINÉES PRÉFABRIQUÉES	
THIS CHIMNEY IS TO BE INSTALLED IN ACCORDANCE WITH MANUFACTURER'S INSTALLATION INSTRUCTIONS. REFER TO INTERTEK'S DIRECTORY OF BUILDING PRODUCTS (https://bpdirectory.intertek.com) FOR DETAILED INFORMATION. NOTE: ON WOOD/COAL BURNING APPLIANCE INSTALLATION, PREMIUM THIRD SHIELDS ARE REQUIRED AROUND THE CHIMNEY FOR INTERIOR COMPLETELY ENCLOSED INSTALLATION EXCEPT ON LISTED FACTORY BUILT FIREPLACES WHEN IT IS CERTIFIED WITH IT AND IDENTIFIED AS SUCH ON THE FIREPLACE LABEL.	CETTE CHEMINÉE DOIT ÊTRE INSTALLÉE CONFORMÉMENT AU MANUEL D'INSTALLATION DU FABRICANT. SE RÉFÉRER AU RÉPERTOIRE D'INTERTEK (https://bpdirectory.intertek.com) POUR PLUS D'INFORMATION. NOTE: LE RACCORDEMENT SUR UN APPAREIL À COMBUSTIBLES SOLIDES REQUIERT L'UTILISATION DES COMPOSANTES COUPE RADIATION PREMIUM AUTOUR DE LA CHEMINÉE SI LA CHEMINÉE EST INSTALLÉE À L'INTÉRIEUR, COMPLÈTEMENT ENCLOSENNÉ, SAUF DANS LE CAS D'UN FOYER PRÉFABRIQUÉ HOMOLOGUÉ AVEC CE CONDUIT ET IDENTIFIÉ COMME TEL SUR SON ÉTIQUETTE D'HOMOLOGATION.	code barre
MODEL - ASHT, DTC, UP: 6", 7", 8" - MODÈLE		
ENGLISH DESCRIPTION xxxxxxxxxxxxxx FRENCH DESCRIPTION xxxxxxxxxxxxxx PRODUCT CODEXXXXXX smart code xxxxxxx		
MM/DD/AAAA Work order		LV MADE IN / FABRIQUÉ AU CANADA NP396 REV.00

LISTING LABELS AND WARNING LABEL

ASHT - 5", 10"

CERTIFIED TO / CERTIFIÉ UL-103 TYPE HT, CAN/ULC 604		 Intertek 4002244
<p>FACTORY-BUILT CHIMNEYS</p> <p>REFER TO INTERTEK'S DIRECTORY OF BUILDING PRODUCTS (https://bpdirectory.intertek.com) FOR DETAILED INFORMATION.</p> <p>MINIMUM CLEARANCE TO COMBUSTIBLES: 2 IN. (50mm) AIR SPACE TO COMBUSTIBLE MATERIALS AND BUILDING INSULATION OR AS ESTABLISHED BY FACTORY FURNISHED FIRESTOP SPACERS AND SUPPORT ASSEMBLY.</p> <p>SUITABLE FOR INTERIOR OR EXTERIOR INSTALLATION</p> <p>THIS CHIMNEY IS TO BE INSTALLED IN ACCORDANCE WITH SECURITY CHIMNEYS INTL.'S INSTALLATION INSTRUCTIONS.</p> <p>CANADIAN APPLICATION:</p> <p>- CERTIFIED TO CAN/ULC 604 FOR CONNECTION TO LIQUID OR GAS FIRED APPLIANCES NORMALLY PRODUCING FLUE GASES OF 540°C OR LESS IN COMPLIANCE WITH CANADIAN CODES ESTABLISHED FOR THIS TYPE OF CHIMNEY.</p> <p>USA APPLICATION:</p> <p>- CERTIFIED TO UL 103 TYPE HT RESIDENTIAL TYPE AND BUILDING HEATING APPLIANCE CHIMNEY PART.</p> <p>USA & CANADA - FACTORY-BUILT FIREPLACES</p> <p>SUITABLE FOR USE WITH SPECIFIC SOLID FUEL FACTORY-BUILT FIREPLACES WHERE SPECIFIED IN THE FIREPLACE MANUFACTURERS INSTALLATION INSTRUCTION.</p>	<p>CHEMINÉES PRÉFABRIQUÉES</p> <p>SE RÉFÉRER AU RÉPERTOIRE D'INTERTEK (https://bpdirectory.intertek.com) POUR PLUS D'INFORMATION.</p> <p>ESPACE LIBRE MINIMAL AUX MATÉRIEL COMBUSTIBLES: ESPACE LIBRE DE 2 PO. (50mm) AUX MATIÈRES COMBUSTIBLES ET À L'ISOLATION DE LA BÂTIMENT OU TEL QU'ÉTABLI PAR LES COUPE-FEU ET SUPPORTS FOURNIS PAR LE FABRICANT.</p> <p>CONVIENT À UNE UTILISATION À L'EXTÉRIEUR OU À L'INTÉRIEUR</p> <p>CETTE CHEMINÉE DOIT ÊTRE INSTALLÉE CONFORMÉMENT AUX MANUEL D'INSTALLATION DE CHEMINÉES SÉCURITÉ INTL.</p> <p>APPLICATION CANADIENNE:</p> <p>- CERTIFIÉ CAN/ULC 604 POUR RACCORDEMENT AUX APPAREILS UTILISANT DES COMBUSTIBLES LIQUIDES OU GAZEUX DÉGAGEANT NORMALEMENT 540°C OU MOINS CONFORMÉMENT AUX NORMES DU CODE CANADIEN POUR CE TYPE DE CHEMINÉE.</p> <p>APPLICATION AMÉRICAINE:</p> <p>- CERTIFIÉ UL 103 TYPE HT PIÈCE DE CHEMINÉE POUR APPAREIL DE CHAUFFAGE RÉSIDENTIEL ET COMMERCIAL.</p> <p>É.U. & CANADA - FOYER PRÉFABRIQUÉ</p> <p>CONVIENT À UNE UTILISATION AVEC DES FOYERS PRÉFABRIQUÉS À COMBUSTION SOLIDE FAITS EN USINE LORSQUE SPÉCIFIÉ DANS LES INSTRUCTIONS D'INSTALLATION DU FABRICANT DE FOYER.</p>	 UP HAUT DIRECTION FLOW DIRECTION ÉCOULEMENT
<p>MODEL - ASHT 5" & 10" - MODÈLE</p> <p>ENGLISH DESCRIPTION xxxxxxxxxxxxxx</p> <p>FRENCH DESCRIPTION xxxxxxxxxxxxxx</p> <p>PRODUCT CODEXXXXXX</p> <p>smart code xxxxxxxx</p>		<p>code barre</p>
 		<p>MM/DD/AAAA LV MADE IN / FABRIQUÉ AU CANADA</p> <p>Work order NP375 REV. 1</p>

ASHT 5", 10" - Accessory

CERTIFIED TO / CERTIFIÉ UL-103 TYPE HT, CAN/ULC 604		 Intertek 4002244
<p>ACCESSORIES</p> <p>FACTORY BUILT CHIMNEYS</p> <p>THIS CHIMNEY IS TO BE INSTALLED IN ACCORDANCE WITH SECURITY CHIMNEYS INTERNATIONAL'S INSTALLATION INSTRUCTIONS.</p> <p>REFER TO INTERTEK'S DIRECTORY OF BUILDING PRODUCTS (https://bpdirectory.intertek.com) FOR DETAILED INFORMATION.</p>	<p>ACCESSOIRES</p> <p>CHEMINÉES PRÉFABRIQUÉES</p> <p>CETTE CHEMINÉE DOIT ÊTRE INSTALLÉE CONFORMÉMENT AUX MANUEL D'INSTALLATION DE CHEMINÉES SÉCURITÉ INTERNATIONALE.</p> <p>SE RÉFÉRER AU RÉPERTOIRE D'INTERTEK (https://bpdirectory.intertek.com) POUR PLUS D'INFORMATION.</p>	
<p>MODEL - ASHT 5" & 10" - MODÈLE</p> <p>ENGLISH DESCRIPTION xxxxxxxxxxxxxx</p> <p>FRENCH DESCRIPTION xxxxxxxxxxxxxx</p> <p>PRODUCT CODEXXXXXX</p> <p>smart code xxxxxxxx</p>		<p>code barre</p>
 		<p>MM/DD/AAAA LV MADE IN / FABRIQUÉ AU CANADA</p> <p>Work order NP376 REV. 1</p>

Warning Label

<p><u>CAUTION</u></p> <p>WARNING: RISK OF FIRE. DO NOT ENCLOSE THIS SHIELD. REMOVE THIS RADIATION SHIELD BEFORE ENCLOSING THE CHIMNEY IN ATTIC SPACE.</p> <p>MAKE SURE NO HOUSE INSULATION IS IN CONTACT WITH THE CHIMNEY ABOVE THE ATTIC RADIATION SHIELD.</p>
<p><u>AVERTISSEMENT</u></p> <p>ATTENTION: RISQUE D'INCENDIE. NE PAS PLACER CE COUPE-FEU DANS UNE ENCEINTE. RETIRER LE COUPE-FEU AVANT D'INSTALLER UNE ENCEINTE AUTOUR DE LA CHEMINÉE DANS LE GRENIER.</p> <p>ASSUREZ-VOUS QU'AUCUN MATÉRIEL ISOLANT NE SOIT EN CONTACT AVEC LA CHEMINÉE AU DESSUS DU COUPE-FEU DE GRENIER.</p> <p style="text-align: right; font-size: small;">ETCS277 REV.01</p>

RECOMMENDATIONS

It is important these installation instructions are followed.

We highly recommend this product be installed and serviced by professionals who are certified in the U.S.A by NFI (National Fireplace Institute) or CSIA or in Canada by WETT (Wood Energy Technology Transfer) or l'APC (l'association des professionnels du chauffage).

Clear the working space to give you freedom of movement during the installation. Be sure to clear any insulation that has been placed over the area where the chimney will penetrate the ceiling above the appliance.

Plan the installation of your appliance and chimney in such a way that both your chimney and your chimney connector (stovepipe) run is as short and straight as possible. By having too long and / or multiple offset installations you will reduce system draft which can affect the operation of your appliance and / or the chimney system. The chimney should be located within the building so as to avoid cutting or altering load bearing members such as joists, rafters, studs, etc. If you have to cut or alter an existing load bearing member, special reframing methods are required which often include doubling of adjacent members. If such a case arises, contact your local Building Code Official regarding local regulations and proper installation methods.

Sections of the ASHT chimney which pass through accessible areas of the building such as closets, storage areas, occupied spaces or any place where the surface of the chimney could be contacted by persons or combustible materials must be enclosed in a chase (framed in). The chase may be fabricated using standard building materials. Drywall mounted on 2" x 4" studs is typically used in this situation. Except for installation in single and two family dwellings, factory-built chimneys shall be enclosed with approved walls having a fire resistance rating equal or greater than that of the floor, wall or roof assemblies through which they pass.

Clearance

The clearances stated in this guide are minimum requirements: if more space is available, use it. Minimum clearances mean leaving unobstructed air space. Do not fill these spaces with any material whatsoever, especially not home insulating material except specified otherwise. If you insulate your attic later, be sure to maintain the necessary clearance.

Inspection

Prior to starting the installation, contact the local building officials in your area, to determine the need for any necessary building permits, and to ensure that your installation will conform with all local, provincial / state and national code requirements. Contact your insurance provider to determine if an inspection by a Certified Professional is required.

Replacement Parts

If a component of your chimney system is damaged it must be replaced by an identical one from Security Chimneys.

APPLICATIONS

WOOD AND COAL STOVES

The ASHT chimney has been designed for use with wood, gas, oil, and coal in residential, commercial and industrial applications, specially developed for use with controlled-combustion stoves and wood burning fireplace .

In the USA, ASHT is listed to UL-103 TYPE HT, 2100°F in diameters of 5, 6, 7, 8 and 10 inches.

In the USA, ASHT "G" (GALVALUME) is listed to UL-103 TYPE HT, 2100°F in diameter 6, 7 and 8 inches.

In Canada, ASHT is listed to ULC-629, 2100° F in diameters 6, 7 and 8 inches for wood/coal application. For that specific application and for interior enclosed installation only, Premium Radiation Shields accessories are required around the chimney. Refer to specific Canadian installation section for proper installation.

In Canada, ASHT is also designed for use with gas or oil fired heating appliances such as furnaces, water heaters, and other appliances, as per ULC-604 in diameters 5 to 10 inches.

If you are planning to install a wood stove, we recommend that you:

1. Choose the right size stove. Do not buy one larger than you need.
2. Connect only one appliance to a chimney.
3. Never overfire your stove. If any part of the stove or stove pipe is glowing red, then you are overfiring. Immediately close the stove's dampers until the system cools. The high temperature caused by overfiring can permanently damage the stove and stove pipe and may overheat nearby combustible walls and furniture.
4. Install the stove and stove pipe as described in the installation instructions accompanying the stove. Be certain to maintain the required clearances to combustible construction.
5. Keep your flue gases between 300°F and 500°F. This will maximize efficiency while minimizing condensation and creosote formation. Do not fill your stove with wood and allow it to smolder for 8 to 10 hours. This condition produces large amounts of creosote in the chimney.

6. Do not burn sea driftwood or treated wood. These combustibles are highly corrosive to all types of stainless steel.

FACTORY BUILT FIREPLACES

ASHT is suitable for use with closed or opened fireplaces certified for use with the ASHT.

When doing so please refer to the fireplace installation instruction to install the chimney.

CREOSOTE - FORMATION AND NEED FOR REMOVAL

Wood burning appliance can quickly create large deposits of creosote in the chimney. Some wood burning appliance can create enough creosote in two weeks to cause a chimney fire.

When wood is burned slowly, it produces tar and other organic vapours, which combine with expelled moisture to form creosote. The creosote vapours condense in the relatively cool chimney flue of a slow-burning fire. As a result, creosote residue accumulates on the flue lining. When ignited this creosote makes an extremely hot fire.

When using a wood stove, we recommend that you::

1. Initially, inspect the chimney system weekly. You will learn how often it will be necessary to clean your chimney.
2. The chimney should be inspected at least once every 2 months during the heating season to determine if a creosote or soot build-up has occurred: if a significant layer of creosote has accumulated (3 mm or 1/8"), it should be removed to reduce the risk of chimney fire.
3. Have your chimney cleaned by a qualified chimney sweep. If you want to clean your chimney yourself: clean your chimney using plastic or stainless steel brushes. Do not use a brush that will scratch the stainless steel interior of your chimney.
4. Do not expect chemical chimney cleaners to keep your chimney clean. Their use does not negate the necessity of periodically inspecting and cleaning your chimney.

WARNING

In Case of Fire: If a flue fire occurs, close all appliance dampers and source of combustion air, and call your Fire Department. Do not use the chimney again, until it has been inspected for possible damage.

NOTE: ALL DIMENSIONS ARE IN INCHES.

CAP REMOVAL FOR MAINTENANCE

To remove cap, unscrew the collar screw to un-tighten the collar.

Pull on the cap to remove it from the chimney.

To put the cap back in place, slide it over the chimney and then tighten the collar using the collar screw.

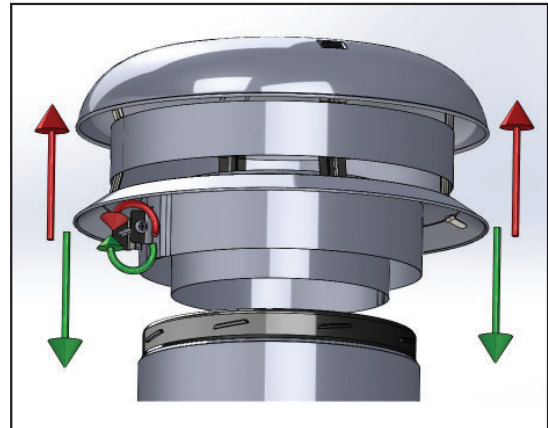

NOTE: DIAGRAMS & ILLUSTRATIONS ARE NOT TO SCALE.

SIZING CHART

CHIMNEY-SIZE	5"	6"	7"	8"	10"
OUTSIDE-DIAMETER	7"	8"	9"	10"	12"
FRAMING DIMENSION REQUIRED					
Reduced Clear. Support (RCS)	--	10 1/8"	11 1/8"	12 1/8"	--
Square support (SSC24)	--	12-1/8"	14-3/8"	14-3/8"	14-3/8"
Wall Thimble (RSM)	11"	12"	13-3/8"	14-3/8"	16-3/8"
Finish support (SFC/SFCA)	--	12-1/8"	14-3/8"	14-3/8"	--
Firestop (BF)	11-3/8"	12-3/8"	13-3/8"	14-3/8"	16-3/8"
Attic Radiation Shield (ARSA)	11-3/8"	12-3/8"	13-3/8"	14-3/8"	16-3/8"
MAX. LENGTH HEIGHT SUPPORTED **					
Tee Support (SME/SMA)	63'	63'	55'	48'	39'
Roof Support (ST)	42'	34'	27'	24'	20'
Radiation Shield Connector Support (RSSR)	--	30'	24'	21'	--
Square Support (SSC24)	--	60'	50'	45'	35'
Reduced Clearance Support (RCS)	--	60'	50'	45'	--
Finish Support (SFC/SFCA)	--	75'	65'	59'	--
Offset/Wall Support (SO-2)	--	28'	24'	20'	14'
Insulated Tee (TI) *	63'	63'	55'	50'	50'
Clearance To Combustibles	2"	2"	2"	2"	2"

Table 1

* When installed on a concrete footing.

** NOTE: If greater height is required, use additional roof supports at intervals not exceeding 30'

ROOF OPENING CHART

CHIMNEY SIZE	5"		6"		7"	
	ROOF HOLE SIZE					
ROOF SLOPE (X/12)	A	B	A	B	A	B
0	11-3/8	11-3/8	12-3/8	12-3/8	13-3/8	13-3/8
2/12	11-3/8	11-1/2	12-3/8	12-1/2	13-3/8	13-1/2
4/12	11-3/8	12	12-3/8	13	13-3/8	14-3/32
6/12	11-3/8	12-11/16	12-3/8	13-13/16	13-3/8	14-15/16
8/12	11-3/8	13-11/16	12-3/8	14-7/8	13-3/8	16-1/16
10/12	11-3/8	14-13/16	12-3/8	16-1/8	13-3/8	17-7/16
12/12	11-3/8	16-1/16	12-3/8	17-1/2	13-3/8	18-29/32

CHIMNEY SIZE	8"		10"	
	ROOF HOLE SIZE			
ROOF SLOPE (X/12)	A	B	A	B
0	14-3/8	14-3/8	16-3/8	16-3/8
2/12	14-3/8	14-9/16	16-3/8	16-19/32
4/12	14-3/8	15-5/32	16-3/8	17-1/4
6/12	14-3/8	16-3/32	16-3/8	18-5/16
8/12	14-3/8	17-1/4	16-3/8	19-11/16
10/12	14-3/8	18-23/32	16-3/8	21-5/16
12/12	14-3/8	20-11/32	16-3/8	23-5/32

Table 2 - Refer to Figure 1

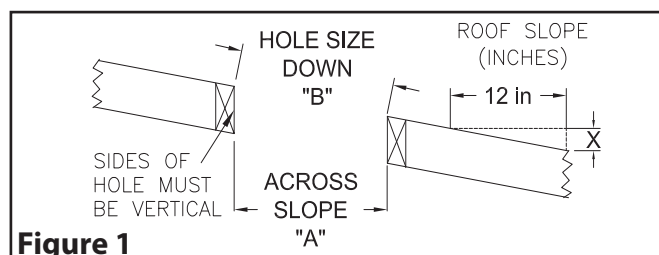

NOTE: DIAGRAMS & ILLUSTRATIONS ARE NOT TO SCALE.

INSTALLATION NOTES

1. The chimney is intended for use with solid, liquid, and gaseous fuel burning appliances.

Allowable flue gas temperature:

Maximum continuous 1200°F

Brief forced firing 1400°F

Tested to 2100°F - 3x 30 min.

2. The maximum height of chimney supported by the various Security Chimneys' supports are outlined on **Table 1**.
3. The supports described in this manual should only be used with Security Chimneys' model ASHT, 5", 6", 7", 8" and 10" factory built chimneys.
4. In order to achieve safe, optimum performance of the appliance, and service life of the chimney, the chimney should be sized correctly for the connected appliance; refer to the appliance manufacturer's instructions.
5. When a firestop is required, it is important to follow the framing dimensions for floor openings as prescribed in this manual. (see **Table 2**).
6. A chimney servicing a fireplace or an incinerator shall not serve any other appliance.
7. The chimney shall extend at least 3 ft above its point of contact with the roof and at least 2ft higher than any wall, roof or adjacent building within 10 ft of it.
8. The maximum height of an unguided chimney above the roof is 5 ft. If the chimney extends more than 5 ft. above the roof, a Universal Roof Brace (BS2) must be used.
9. The clearance between single wall pipe and unprotected combustible material must not be less than 18" (see National Building Code and NFPA 211) except: The distance between the vertical stove pipe and the ceiling may be less than 18" and will be established by the finish or ceiling support.
10. Multi-Story: Consult local building codes for requirements in your area. In the U.S., the National Fire Protection Association Standard #211 states: "Factory-built chimneys that pass through floors of buildings requiring the protection of vertical openings shall be enclosed with approved walls having a fire resistance rating of not less than one hour when such chimneys are located in a building less than 4 stories in height, and not less than 2 hours when such chimneys are located in a building more than 4 stories in height."
11. Do not fill the 2" space around the chimney with household insulation or any other material unless specified

otherwise. Insulation placed in this area could prevent proper air circulation around the chimney and may cause adjacent combustible materials to overheat.

12. Self-tapping stainless screws are not required, but may be used to reinforce the connection and avoid accidental unlocking of chimney lengths. Use only 1/2" self-tapping screws. Do not penetrate the inner wall of the chimney.
13. When penetrating an exterior wall or ceiling/roof assembly, the vapor barrier must be repaired. This is easily accomplished by attaching the vapor barrier to the outer perimeter of any wall thimble, Firestop, or ceiling support component using approved sealant or tape, while also maintaining the minimum clearances-to-combustibles to the chimney's outer wall. When penetrating the building envelope, the gap between the outer layer of chimney and any Firestop or wall thimble can be sealed using high-temperature rated (600°F) silicone caulking. Should you require further clarification, consult your local authority having jurisdiction.
14. The safe operation of a factory-built chimney assembly is based on the use of parts supplied by the manufacturer and the performance of the assembly may be affected if the combination of these parts is not used in actual building construction.

Acceptance of the assembly is void if the installation instructions are not followed.
15. Provisions must be made to ensure that all interior portions of the chimney be accessible for inspection and cleaning.

 **WARNING**

The clearance between the chimney and combustible material must not be less than 2", except where established by the support. Do not fill this area with insulation unless directed otherwise in these instructions.

1

GENERAL INSTALLATION NOTES (CONT'D) (USA)

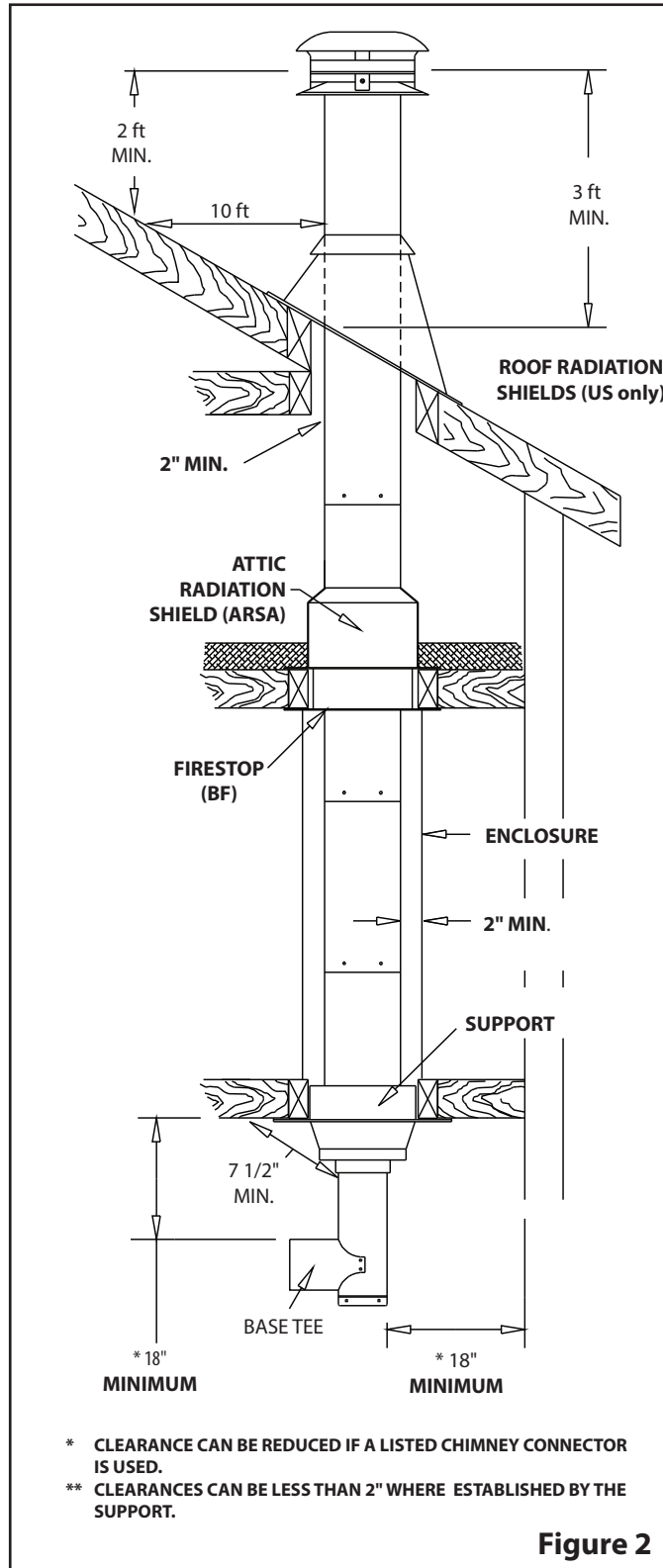

2

INTERIOR STRAIGHT INSTALLATION - SINGLE FLOOR (USA)

REDUCED CLEARANCE SUPPORT (RCS)

When using the Reduced Clearance Support (RCS) at the attic level, the use of the attic radiation shield is not required. The Reduced Clearance Support (RCS) acts as an attic radiation shield when installed with insulation and a collar (provided) (see **figure 3**).

NOTE: A Finishing Support (FSC) combined with an Attic Radiation Shield (ARSA) can also be used for this application. Refer to **Section 3: FINISHING SUPPORT (SFC)** for installation guide.

Step 1: Locate the chimney in a convenient place as near as possible to the appliance outlet.

Step 2: Cut and frame the opening in the ceiling and roof where the chimney will pass.

NOTE: It is important to follow the framing dimensions for floor openings as prescribed in **Table 1**.

Step 3: From below, push the Reduced Clearance Support into the framed opening in the ceiling. Ensuring the support is level, attach the support to the framed opening using (12) - 3" spiral nails or #8 x 1 1/2" wood screws (see **Figure 3**). At least 3 1/2" of the support must extend into the room. Screw the Finish Trim (included) to the ceiling.

NOTE: At least 3 1/2" of the support must extend down below the finished ceiling. This ensures minimum clearances are maintained to stovepipe. Fix the Finish Trim around the support using supplied screws.

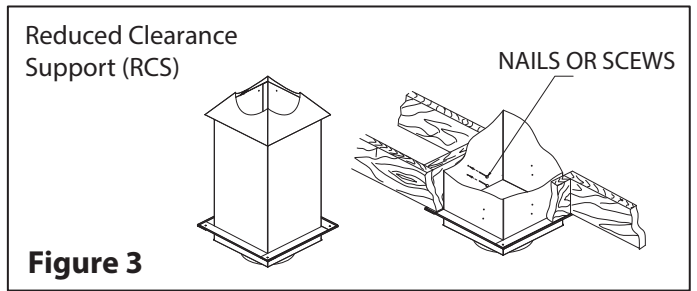

Figure 3

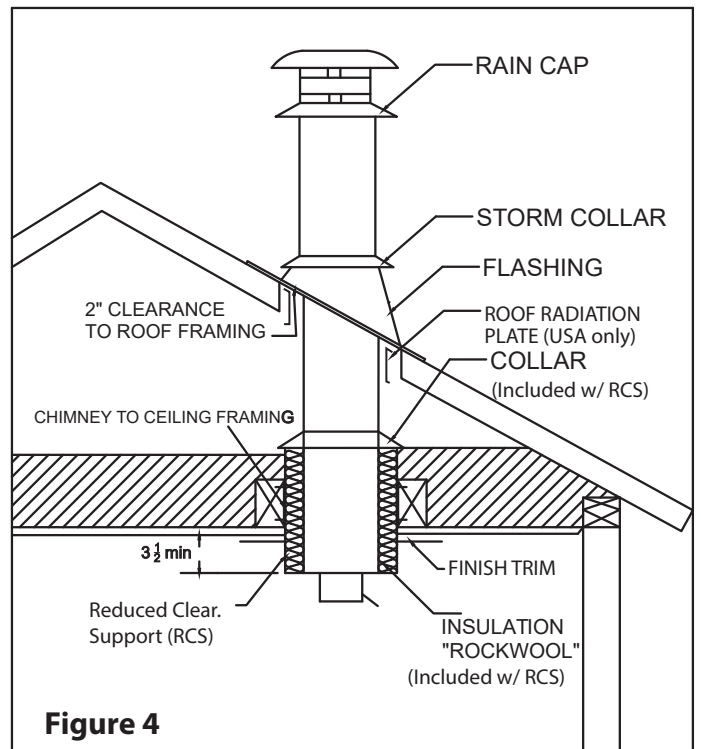

Figure 4

CHIMNEY SIZE	FRAMING DIMENSION	
	Reduce Clearance Support	ROOF
6"	10-1/8" x 10-1/8"	12-3/8" x 12-3/8"
7"	11-1/8" x 11-1/8"	13-3/8" x 13-3/8"
8"	12-1/8" x 12-1/8"	14-3/8" x 14-3/8"

Table 3

2

INTERIOR STRAIGHT INSTALLATION - SINGLE FLOOR (USA)(CONT'D)

Step 4: Place first chimney length into the support. Twist to lock into place. Wrap the insulation pad around the chimney section. Slide insulation pad into the space between the chimney section and support making sure the insulation makes contact with the bottom of the support. Additional pieces of insulation can be loosely tucked down within corners. Do not compress insulation. This reduces effectiveness.

NOTE: If needed a Support Extension (SE) can be attached to the support to increase its height. Refer to **Section 4: REDUCED CLEARANCE SUPPORT EXTENSION (SE)**.

NOTE: Make sure arrow on pipe label is pointing upward.

Step 5: The square-to-round collar (included) features a fixing tab and slot. To install, wrap the collar around the chimney.

Slide it down on top of the RCS Support.

Pull the sides of the collar together while inserting the collar's tab through the slot.

Once tight, fold the tab over to secure the collar. Check fit to ensure the collar completely covers the top of the support.

Step 6: Stack the next chimney length on the first length. Be sure that the male and female threads are not in line when putting the lengths together. Turn the chimney clockwise to lock it in place. Continue until the required chimney height is reached.

Step 7: **ROOF RADIATION SHIELD**

Install the Roof Radiation Shield in the roof frame opening. This shield consists of (4) metal plates supplied with the Roof Flashing. Nail one plate to each side of the frame opening using (2) - 2 1/2" nails, making sure each plate is centered.

Step 8: **ROOF FLASHING INSTALLATION**

Put the roof flashing in place. Seal the joint between the roof and the flashing with roofing compound.

For sloping roofs, place the flashing under the upper shingles and on top of the lower shingles. Nail the flashing to the roof using nails. Place the storm collar around the chimney and slide down on top of the flashing.

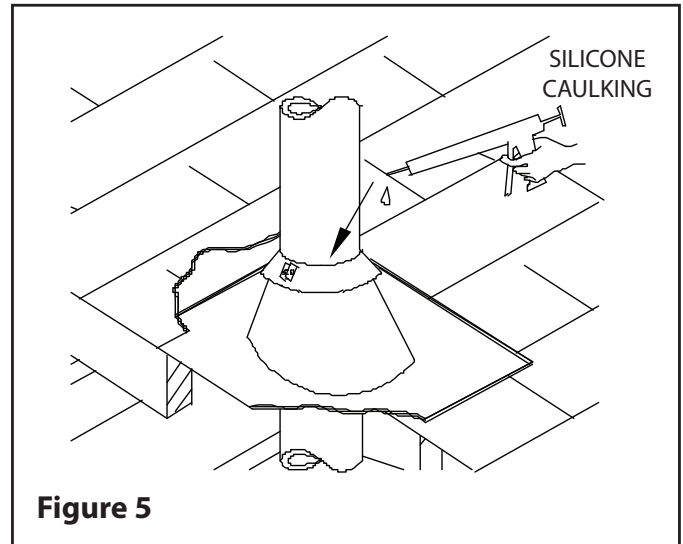

Step 9: Tighten the collar using the supplied bolt. Make sure the joint is properly caulked (**see Figure 5**).

Step 10: Attach the rain cap to the top of the chimney.

3

INTERIOR STRAIGHT INSTALLATION - MULTIPLE FLOOR (USA)

If using the Reduced Clearance Support (RCS), refer to Table 3 for dimensions. When used for this application, the square-to-round collar is not used.

When using the RCS, installer must always consider obstacles above that could encroach on or compromise clearances truss top chord and diagonal webs etc. Clearance reduction only applies to portion of chimney protected by the support and the support extension.

FINISHING SUPPORT (SFC)

Step 1. Locate the chimney in a convenient place as near as possible to the appliance outlet.

Step 2. Cut and frame the openings in the floor, ceiling and roof where the chimney will pass.

NOTE: It is important to follow the framing dimensions for the floor openings prescribed in this manual.

CHIMNEY SIZE	HOLE SIZE	
	FINISH SUPPORT (SFC)	ATTIC RADIATION SHIELD (ARSA) & (ROOF)*
5"	12-1/8" x 12-1/8"	11-3/8" x 11-3/8"
6"	12-1/8" x 12-1/8"	12-3/8" x 12-3/8"
7"	14-3/8" x 14-3/8"	13-3/8" x 13-3/8"
8"	14-3/8" x 14-3/8"	14-3/8" x 14-3/8"
10"	---	16-3/8" x 16-3/8"

Table 4
* For sloping roofs, see Table 2

Step 3. From below push the finish support into the framed opening. Nail or screw the support to the framed box using (12) 3" spiral nails or #8 x 1 1/2" wood screws (see Figure 6).

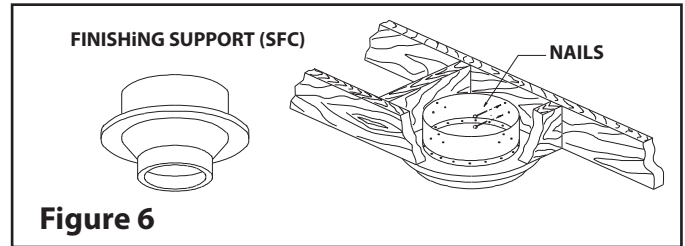

Figure 6

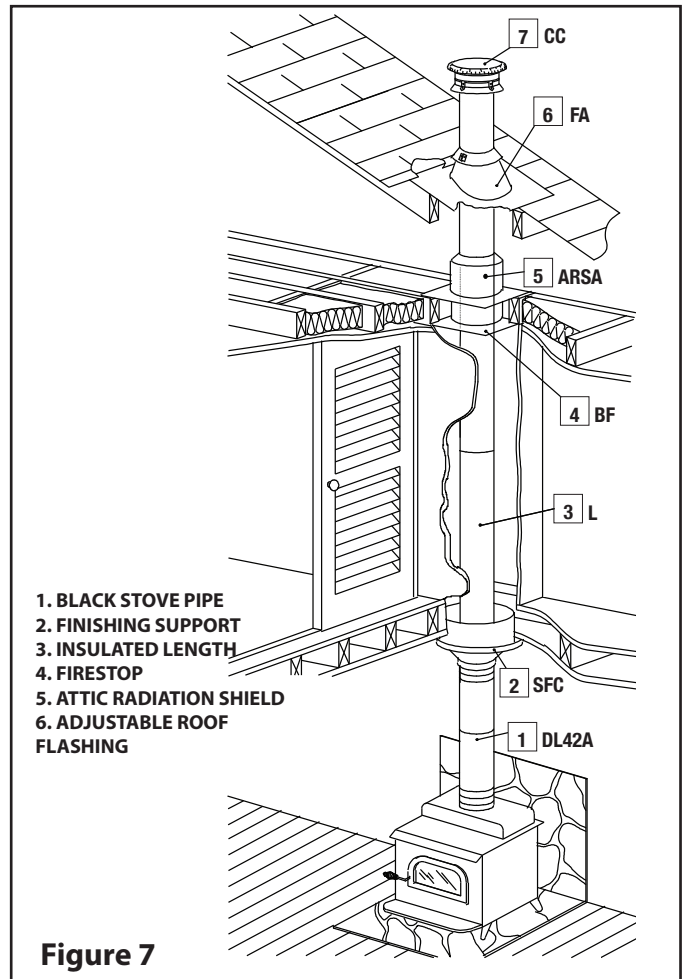

Figure 7

3

INTERIOR STRAIGHT INSTALLATION - MULTIPLE FLOOR (USA)

Step 4. Put the first chimney length in the support. Turn it clockwise to lock it in place (see **Figure 7**).

NOTE: Arrow on pipe label must be pointing up.

Step 5. From below, install a Firestop (BF) in each floor through which the chimney passes.

Step 6. Stack the next chimney length on the first length. Be sure that the male and female threads are not in line when putting the lengths together. Turn the chimney clockwise to lock it in place. You may add a 1/2" stainless steel self tapping screw to prevent accidental unlocking. Continue until the required chimney height is reached.

Step 7. At the attic level, install a Firestop (BF) on underside of frame at ceiling. The Attic Radiation Shield (ARSA) must be installed on its baseplate atop the frame from above (see **Figure 8**).

Install the Roof Radiation Shield in the roof frame opening. This shield consists of four metal plates supplied with the roof flashing. Nail one plate to each side of the joist using (2) - 2 1/2" nails.

Step 8. **ROOF FLASHING INSTALLATION**

Put the roof flashing in place. Seal the joint between the roof and the flashing with roofing compound.

For sloping roofs, place the flashing under the upper shingles and on top of the lower shingles. Nail the flashing to the roof using roofing nails. Place the storm collar over the chimney and the flashing. Tighten it with the bolt supplied making sure the joint is properly caulked (see **Figure 9**).

Step 9. Attach the rain cap to the top of the chimney.

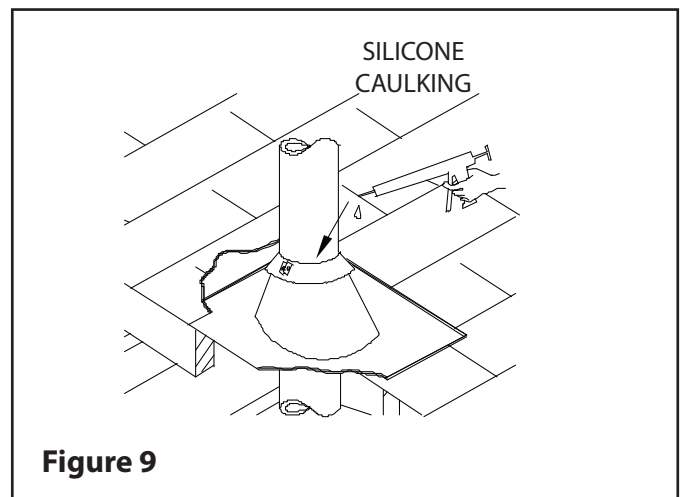
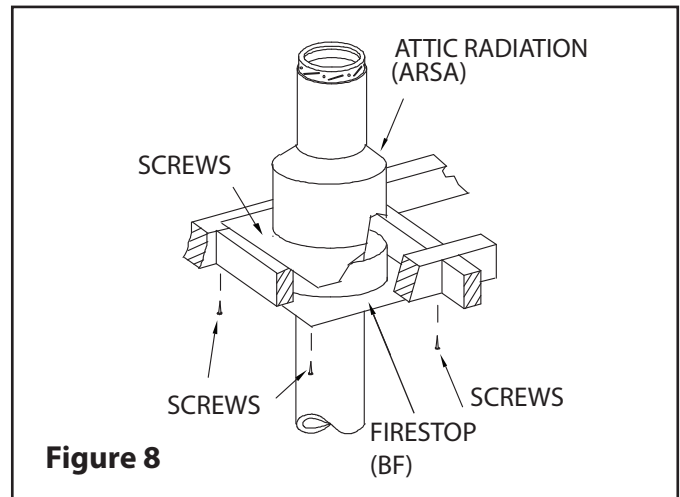

4

INTERIOR INSTALLATION CATHEDRAL CEILING (USA)

REDUCED CLEARANCE SUPPORT (RCS)

NOTE: The Reduced Clearance Support (RCS) comes with a collar. It can be discarded for a Cathedral Ceiling application, it is not required.

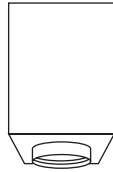

RCS

Step 1: Locate the chimney in a convenient location as near as possible to the appliance outlet. Cut and frame an opening in the roof for the support (see **Table 5**). The sides of this opening must be vertical (see **Figure 11**).

Step 2: From above, place the support in the opening.

NOTE: The bottom portion of the support must project below the ceiling. Distance will vary according to pitch (see **Table 6**). The minimum horizontal distance between single wall stove pipe and adjacent wall surfaces is 18".

Step 3: Use a level to ensure the support is vertical. If the support extends above the roof, cut it flush with the top of the roof. Attach the support to the framed opening using (12)-3" spiral nails or #8 x 1 1/2" wood screws (see **Figure 10**).

Step 4: Place first chimney length into the support. Twist to lock into place. Wrap the insulation pad around the chimney section. Slide insulation pad into the space between the chimney section and support making sure the insulation makes contact with the bottom of the support. Additional pieces of insulation can be loosely tucked down within corners. Do not compress insulation. This reduces effectiveness.

Where desired, an extension (SE) is available for the support. This may be needed in steeper cathedral applications. Approved insulation can be used within the extension. It must be listed/compliant with ASTM E136/ULC S114 as non-combustible, have a melting temperature above 2000°F/1100°C, and be water resistant with low moisture absorption. Materials such as rockwool or mineral wool qualify.

IMPORTANT: Approval to include additional insulation around the chimney applies only within the (RCS) and (SE) support extension. DO NOT attempt to field-insulate around the pipe at any other location or within any other uninsulated component offered by Security Chimney.

TO CONTINUE INSTALLATION REFER TO SECTION 6: ROOF SUPPORT (ST)

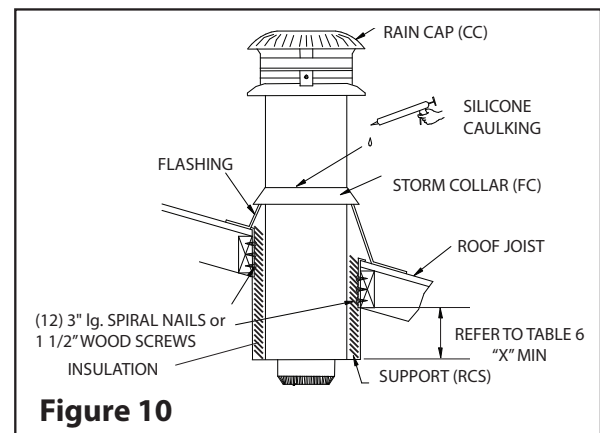

Figure 10

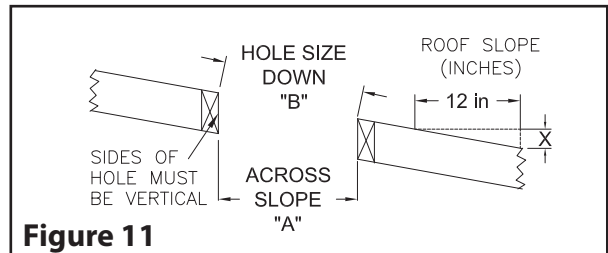

Figure 11

Chimney Size	Frame opening. (Reduce Clearance Support)					
	6"		7"		8"	
Roof Slope (X/12)	A	B	A	B	A	B
0	10-1/8	10-1/8	11-1/8	11-1/8	12-1/8	12-1/8
2/12	10-1/8	10-1/4	11-1/8	11-1/4	12-1/8	12-1/4
4/12	10-1/8	10-5/8	11-1/8	11-3/4	12-1/8	12-3/4
6/12	10-1/8	11-1/4	11-1/8	12-1/2	12-1/8	13-1/2
8/12	10-1/8	12-1/8	11-1/8	13-1/4	12-1/8	14-1/2
10/12	10-1/8	13-1/4	11-1/8	14-1/2	12-1/8	15-7/8
12/12	10-1/8	14-1/4	11-1/8	15-3/4	12-1/8	17-1/8

NOTE: ALL DIMENSIONS ARE IN INCHES.

Table 5

NOTE: DIAGRAMS & ILLUSTRATIONS ARE NOT TO SCALE.

4

INTERIOR INSTALLATION CATHEDRAL CEILING (USA), (CONT'D)

Reduce Clearance Support Extension (SE)

Steep pitched cathedral ceilings may require the use of a Support Extension (SE). This piece fits down inside the reduced clearance support and can be adjusted to increase the support's length by up to 22".

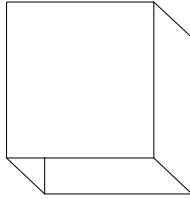

SE

The extension is attached to the support using the eight metal screws provided. Be sure there is at least a 2" overlap where the extension joins the support.

NOTE: Refer to Step 4 (**Section 4: RCS**) regarding additional insulation required with this extension.

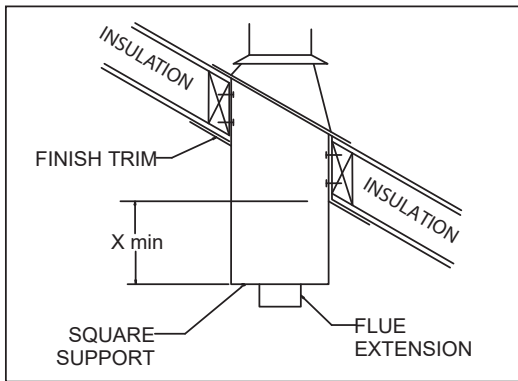

Figure 12

Slope	X min
0/12 - 2/12	3 ½"
2/12 - 7/12	5 ½"
7/12 - 12/12	6 ¾"
12/12 - 24/12	7 ½"
24/12	12 ½"

Table 6

4

INTERIOR INSTALLATION WITH CATHEDRAL CEILING (USA), (CONT'D)

SQUARE SUPPORT (SSC24)

This support is similar in application and installation as the Reduced Clearance Support. Install it using the instructions on **Section 4: REDUCED CLEARANCE SUPPORT (RCS)** (refer to **Figure 13** for visual references).

Approved insulation can be used within the extension and support surrounding the chimney. It must be listed/compliant with ASTM E136/ULC S114 as non-combustible, have a melting temperature above 2000°F/1100°C, and be water resistant with low moisture absorption. Materials such as rockwool qualify.

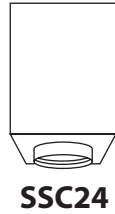

SSC24

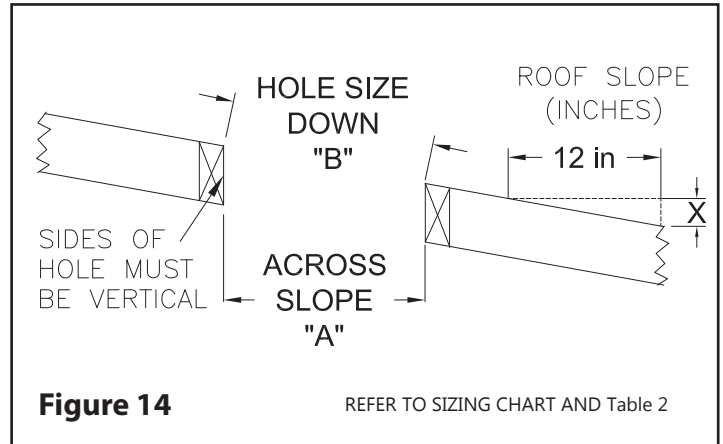
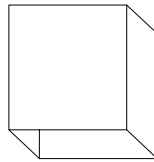

Figure 14

REFER TO SIZING CHART AND Table 2

SUPPORT EXTENSION (PS24) (For Square Support only)

Steep pitched cathedral ceilings may require the use of a Square Support extension (PS24). This piece fits down inside the square support and can be adjusted to increase the support's length by up to 22"



PS24

The extension is attached to the support using the eight metal screws provided. Be sure there is at least a 2" overlap where the extension joins the support.

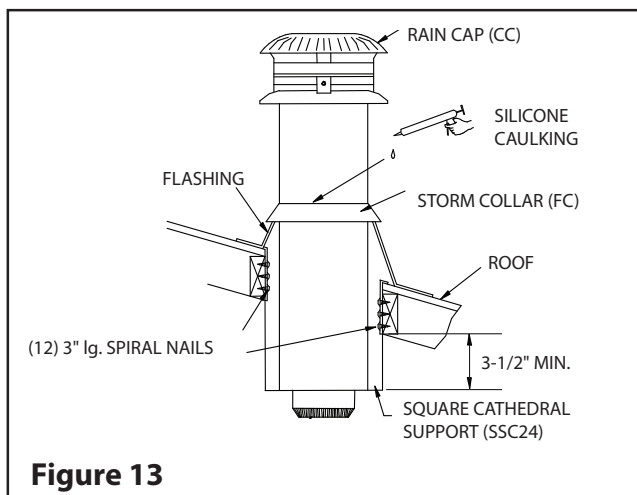

Figure 13

5

OFFSET DEVIATION (USA)

OFFSET CHIMNEY

It may be necessary to offset the chimney to clear an obstruction such as a joist or truss, or to position the chimney close to the ridge cap. A maximum of two offsets (4 elbows in all) is allowed in a chimney. The chimney must not be inclined more than 30°. The minimum chimney height when using 15° offsets is 10' and 15' if using 30° offsets

The maximum length of unsupported offset chimney is 6'. If the offset chimney is longer than 6', then it must be supported at 6' intervals using a Wall Support (SO-2) or a Roof Support (ST).

WARNING

A support must always be installed right above each offset (two elbows) to support the chimney above the offset.

INSTALLATION INSTRUCTIONS

Install the required support and the chimney as described in the previous pages of installation instructions. When you reach the height at which the elbow will be installed, proceed as follows:

Step 1. Install the insulated offset elbow on the vertical chimney length. Turn it in the required direction and fasten it to the chimney with the (4)-1/2" metal screws provided.

Step 2. Place the required offset chimney length (see **Table 7**) on the elbow. Turn it clockwise to lock it in place.

Step 3. Use another elbow to turn the chimney vertically. Again secure the elbow to the chimney length using the (4)-1/2" metal screws.

Step 4. Install the remaining chimney as described in the instructions for the Roof Support (See **Section 6**).

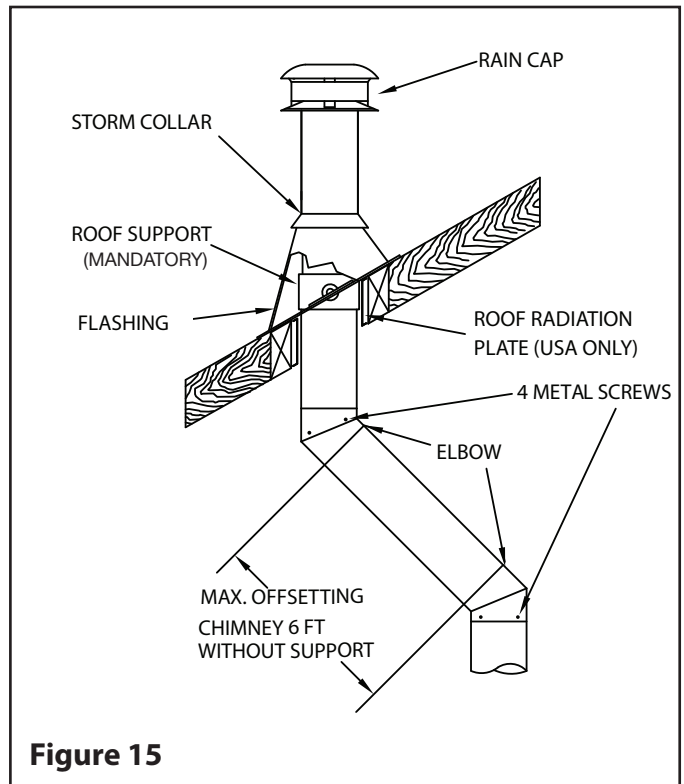

Figure 15

INSTALLATION CALCULATIONS

Determine whether offset is required based on obstacles above that must be avoided (see **Figure 15**). Refer to **Table 7** to determine the elbows required as well as the insulated length needed. If required, an adjustable length can be used to offset exact distance required.

5

OFFSET DEVIATION (USA), CONT'D

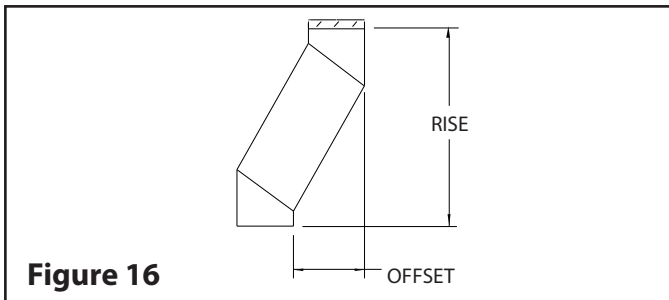

Figure 16

OFFSET & RISE CHART MODEL ASHT (5", 6", 7", 8", 10")

ANGLE	DIA.	INCHES	ONE LENGTH BETWEEN ELBOWS					
			8	12	18	24	36	48
15°	5", 6", 7", 8", 10"	Offset	3-5/16	4-5/16	5-7/8	7-7/16	10-1/2	13-5/8
		Rise	15-11/16	19-9/16	25-3/8	31-3/16	42-3/4	54-3/8
30°	5", 6", 7", 8", 10"	Offset	7-7/16	9-7/16	12-7/16	15-7/16	21-7/16	27-7/16
		Rise	20	23-1/2	28-11/16	33-7/8	44-1/4	54-11/16

ANGLE	DIA.	INCHES	TWO LENGTHS BETWEEN ELBOWS					
			8 & 48	12 & 48	18 & 48	24 & 48	36 & 48	48 & 48
15°	5", 6", 7", 8", 10"	Offset	15-3/8	16-7/16	18	19-1/2	22-5/8	25-3/4
		Rise	60-15/16	64-13/16	70-9/16	76-3/8	87	99-9/16
30°	5", 6", 7", 8", 10"	Offset	30-13/16	32-13/16	35-13/16	38-13/16	44-13/16	50-13/16
		Rise	60-9/16	64	69-1/4	74-7/16	84-13/16	95-1/4

Table 7

Note: All dimensions are in inches.

6

OFFSET DEVIATION (USA)

ROOF SUPPORT (ST)

The Roof Support has three possible uses:

It may be used to support a chimney from the roof. It adjusts to any roof pitch.

It may be used on a floor, ceiling or roof above an offset to support the chimney above the offset.

It may be used on a floor, ceiling or roof as a supplementary support when the chimney height exceeds that of the primary support. (See maximum length height supported, **Table 1**).

INSTALLATION INSTRUCTIONS

With the chimney extending through the opening in the roof, ceiling or floor proceed as follows (Refer to **Figure 18** for visual references):

- Step 1. Install the roof radiation shields in the roof joists. These shields consist of four metal plates. Nail one plate to each side of the framing using (2) 2-1/2" nails.
- Step 2. Assemble the Roof Support's Collar to fit your chimney diameter. Continue to assemble the support as described in the instructions supplied with the support.
- Step 3. Slip the assembled Roof Support down over the stainless steel chimney until its brackets rest on the roof or floor. Tighten the collar around the chimney, (see **Figure 17**).
- Step 4. Center the chimney and nail or screw the support to the roof or floor using (8) - 2-1/2" nails or (8) N^o. 8 - 1-1/4" wood screws. (**Figure 16**).
- Step 5. Install the remaining chimney lengths, until the required chimney height is reached.

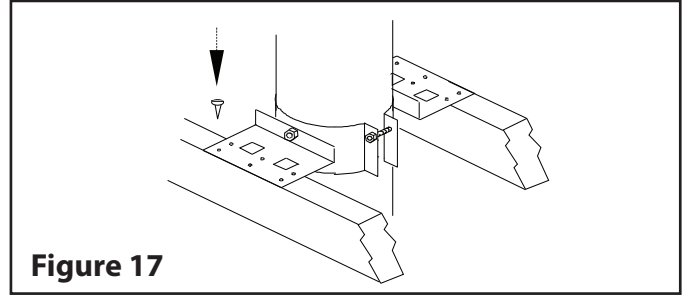

Figure 17

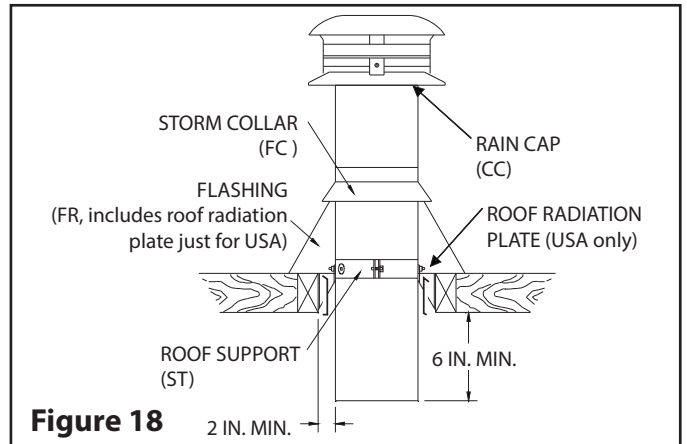

Figure 18

Step 6. **ROOF FLASHING INSTALLATION**

Put the roof flashing in place. Seal the joint between the roof and the flashing with roofing compound.

For sloping roofs, place the flashing under the upper shingles and on top of the lower shingles. Nail the flashing to the roof using nails. Place the storm collar around the chimney and slide down on top of the flashing. Tighten it with the bolt supplied making sure the joint is properly caulked (see **Figure 9**).

Step 7. For Cap installation, also refer to **section CAP REMOVAL FOR MAINTENANCE**.

6

EXTERIOR INSTALLATION (USA)

This chimney will provide optimum performance when installed within the heated space of a building. The consequences of installing the chimney outdoors, up the exterior wall of a building could result in:

- Back-drafting during cold weather when the connected appliance is not operating
- Weak, unstable draft
- Increased creosote accumulation
- Increased potential for condensation of water vapor in the chimney flue.
- Decreased efficiency of the connected appliance.

If you do install an exterior chimney, we recommend that you enclose it using an insulated enclosure.

INSTALLATION NOTES

CAUTION:

MAKESHIFT INSTALLATION ON ROOF ASSEMBLIES CAN CAUSE A HAZARDOUS ENVIRONMENT.

1. The chimney may be enclosed or unenclosed.
2. Maintain 2" clearance to combustible materials. Do not fill the 2" space around the chimney with insulation or any other material.
3. A Wall Strap or Re-Support must be used to secure the chimney to the wall when used on an exterior wall. Maximum distance between wall bands is 8'.
4. The horizontal chimney length passing through the wall must project a minimum of 5" and no more than 24" beyond the inside wall. Minimum projection is required to ensure appropriate clearances are maintained once stovepipe is installed.
5. If an exterior installation is to be enclosed, allow for access to base of tee to facilitate required cleaning.
6. The minimum distance between the bottom of the Tee or Support and any horizontal combustible is 2" by using an insulated tee cap (TCI).

WALL-SUPPORT

When a chimney is used along a wall, this support may be used to support the chimney. The height of chimney supported is shown in supported height See **Table 1**.

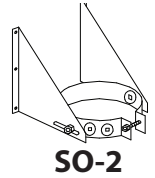

INSTALLATION INSTRUCTIONS

Install the support as follows (see **Figure 19**):

- Step 1. Assemble the collar to fit your chimney diameter. Continue to assemble the support as described in the instructions supplied with the support.
- Step 2. Slip the support down over the chimney to the proper location.
- Step 3. Tighten the collar around the chimney.
- Step 4. Attach the support brackets to the wall using (8) 3" nails or (8) N°. 10 x 1-1/4" wood screws.

NOTE: Be sure that the support attaches to a framing and not merely to dry wall or siding.

Step 5. Continue installing the chimney.

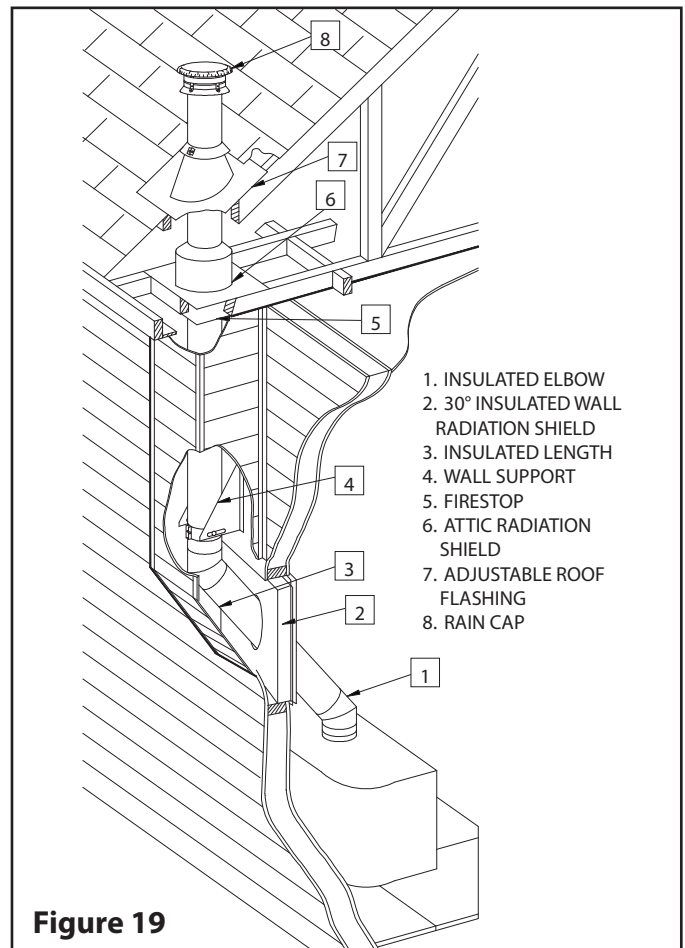

Figure 19

NOTE: DIAGRAMS & ILLUSTRATIONS ARE NOT TO SCALE.

6

EXTERIOR INSTALLATION (USA), CONT'D

WALL SUPPORT

INSTALLATION INSTRUCTIONS

Step 1. Determine where the chimney will pass through the wall.

- For concrete walls cut an opening as per **TABLE 8**.
- For combustible walls cut and frame a hole as per **TABLE 8**, midway between the wall studs (see **Table 8** below for sizing).

Normally wall studs are placed at 16" on center. With the hole midway between them, the support will fasten to these studs and thus ensure a strong attachment to the wall (see **Figure 21**).

Step 2. Wood walls: Place the exterior half of the Wall Thimble (RSM-2) in the opening from the outside. Nail in place using (4) 2" nails or 1" screws. This Wall Thimble is adjustable from 7" to 12" (see **Figure 22**). Make sure the insulation pad is cut to the desired length according to the wall thickness. Place the interior half of the Wall Thimble inside the exterior half of the Wall Thimble. For walls thicker than 12", a shield extension can be field-fabricated using minimum 26-gauge galvanized sheet metal.

Ensure the opening for the chimney to pass through is straight and level. Screw the inner thimble in place with the provided screws (see **Figure 23**).

The cavity surrounding the wall thimble metal shield can be filled with insulation (see **Figure 23**).

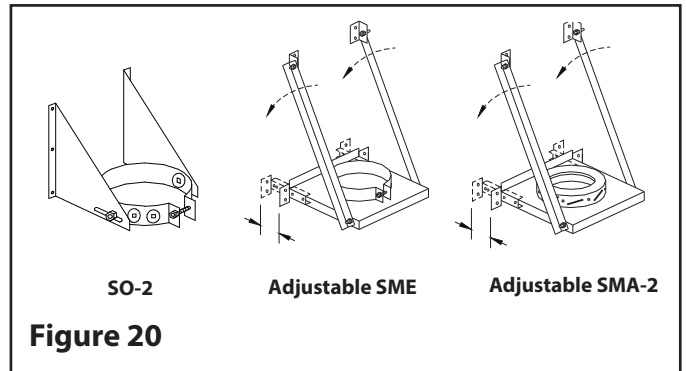

Figure 20

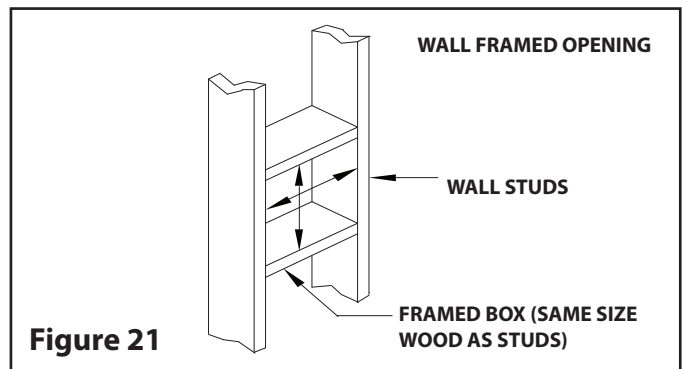

Figure 21

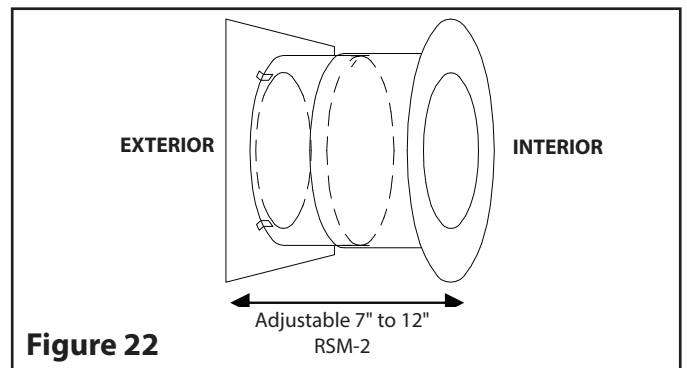

Figure 22

CHIMNEY SIZE	OPENING SIZE	
	COMBUSTIBLE	CONCRETE
5"	11" x 11"	7-3/4"
6"	12" x 12"	8-3/4"
7"	13-3/8" x 13-3/8"	9-3/4"
8"	14-3/8" x 14-3/8"	10-3/4"
10"	16-3/8" x 16-3/8"	12-3/4"

Table 8

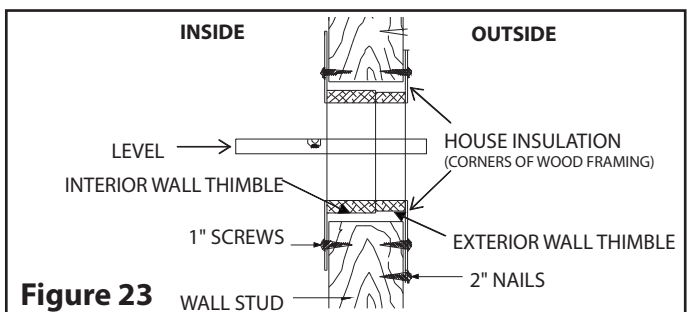

Figure 23

6

EXTERIOR INSTALLATION (USA), CONT'D

Step 3. The minimum length of insulated chimney required to pass through the wall will be thickness plus 7". The insulated chimney must extend at least 5" into the room beyond the finished wall. Insert this chimney length in the side branch of the insulated tee. Turn it clockwise to lock it in place. Seal this joint by wrapping it with the aluminum tape supplied with the tee. Mount the insulated tee on the support so that the chimney length which will go through the wall is perpendicular to the side of the support that will fasten to the wall.

NOTE: The supports (SO-2 or SME) can be installed above the Tee. (See **Figure 25A**).

Step 4. This step will require 2 people: (see **Figure 24**). Insert the chimney length of this tee-support assembly into the hole in the wall. Using a level, ensure the tee is vertical, then attach the support to the wall using (8) N^o. 10 x 1 - 1/4" wood screws or 4" spiral nails.

NOTE: To provide sufficient strength, the nails must be driven into the wall studs. For concrete walls, the support should be attached using (8) 1/4" x 2" lag bolts.

Step 5. Attach the clean-out cap to the Tee Support or Tee.

Step 6. Attach the flue extension to the horizontal chimney length.

Step 7. Stack a chimney length on top of the Tee. Turn it clockwise to lock it in place. Continue until the required chimney height is reached.

NOTE: At 8' intervals, attach the chimney to the wall using a Wall Strap or Wall Support.

Step 8. If the chimney passes through the roof, cut a hole large enough to provide 2" clearance between the chimney and the roof. For pitch roof. See roof opening chart **See roof opening chart Table 2**

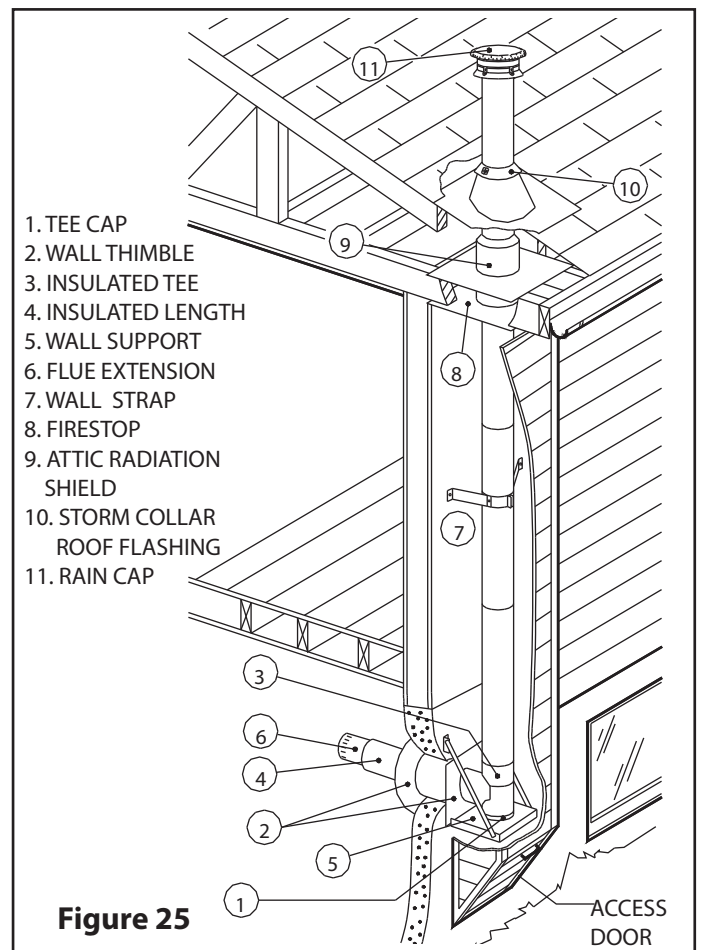
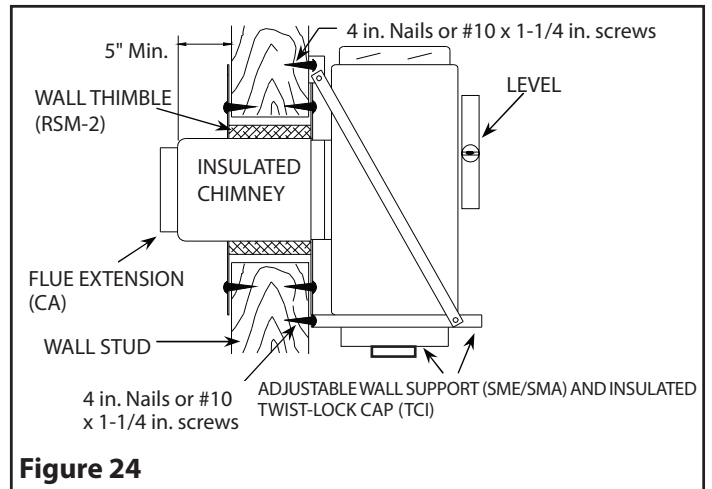

Install the Roof Radiation Shield in the roof hole framing.

To continue, SEE STEP 7, on SECTION 2: REDUCED CLEARANCE SUPPORT (RCS)

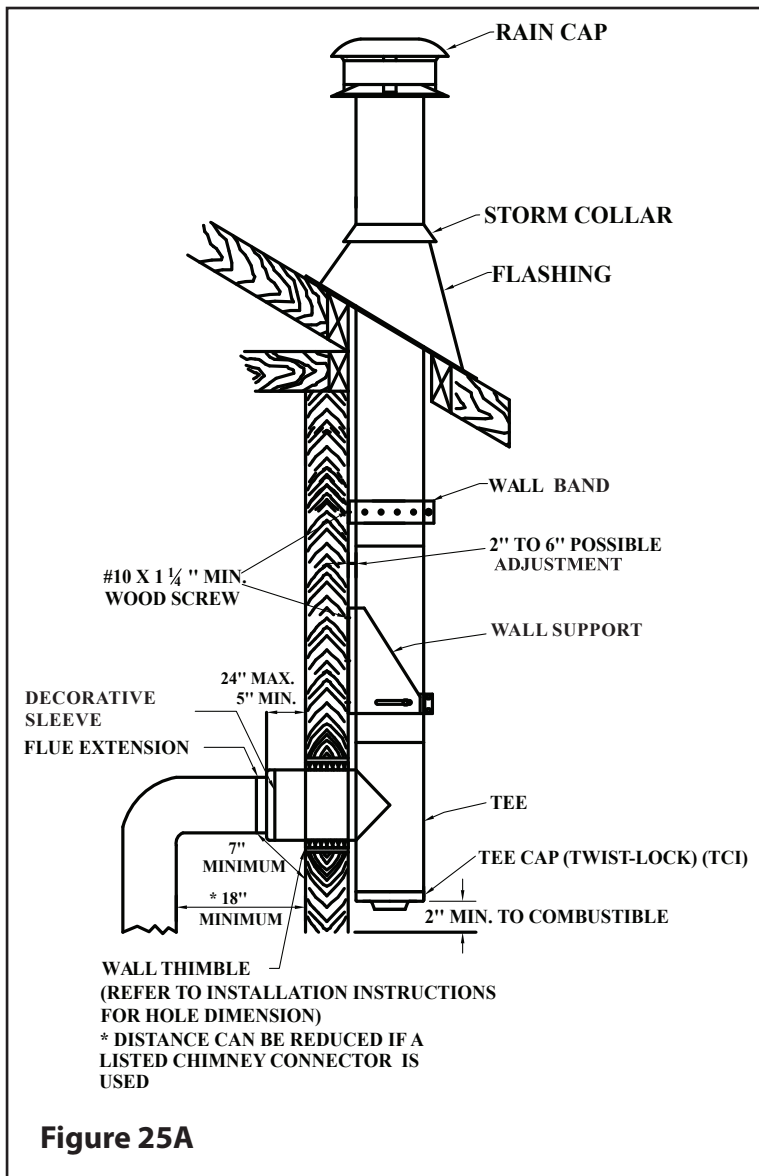

INSTALLATION NOTES

1. The chimney is intended for use with solid, liquid, and gaseous fuel burning appliances. In Canada, only 6", 7" and 8" dia. can be used on any solid fuel appliances. 5" and 10" can be used on listed wood fireplaces.

Allowable flue gas temperature:

Maximum continuous 1200° F (650°C)
Brief forced firing 1400°F (760°C)
Tested to 2100°F (1150°C) 3x - 30 min.

- a. On wood or coal appliance applications and in areas where the chimney is completely enclosed in an interior house installation, it is required to install Premium Radiation Shield (Telescopic **TRLRS-3** or Flexible **FLRS-3**) around the chimney and a Radiation Shield Connector (**RSC-3**) at the ceiling level. (See Figure 26).
 - b. For venting of gas or oil burning appliances, Premium Radiation Shield are not required, even where the chimney is enclosed.
 - c. With factory-built, wood-burning fireplaces, Premium Radiation Shields are usually not required. Refer to the manufacturer's certified installation instructions provided with the fireplace to confirm".
2. The maximum height of chimney supported by the various Security Chimneys' supports are outlined on **Table 1**.
 3. The supports described in this manual should only be used with Security Chimneys' model ASHT, 5", 6", 7", 8" and 10" factory built chimneys.
 4. In order to achieve safe, optimum performance of the appliance, and service life of the chimney, the chimney should be sized correctly for the connected appliance; refer to the appliance manufacturer's instructions.
 5. When a firestop is required, it is important to follow the framing dimensions for floor openings as prescribed in this manual. (see **Table 2**).
 6. A chimney servicing a fireplace or an incinerator shall not serve any other appliance.
 7. When proceeding to the installation of radiation shields and/or attic insulation shields, the vertical height of the attic insulation shield or radiation shield above attic construction material should accommodate the amount of insulation as required by the National Building Code.
 8. The chimney shall extend at least 3 ft above its point of contact with the roof and at least 2ft higher than any wall, roof or adjacent building within 10 ft of it.
 9. The maximum height of an unguided chimney above the roof is 5 ft. If the chimney extends more than 5 ft. above the roof, a Universal Roof Brace (BS2) must be used.
 10. The clearance between single wall pipe and unprotected combustible material must not be less than 18" (see National Building Code and CSA-B365) except: The distance between the vertical stove pipe and the ceiling may be

less than 18" and will be established by the finish support.

11. Where a factory-built chimney assembly extends through any story above that on which the connected appliance is located, it is to be provided with an enclosure which will maintain its required clearances. Apart from the above, installations in one and two family dwellings, a factory-built chimney that extends through any zone above that on which the connected appliance is located is to be provided with an enclosure having a fire resistance rating equal to or greater than that of the floor or roof assemblies through which it passes.

In addition, NFPA211 requires rated enclosures of any factory-built chimneys that pass through floors of buildings that the protection of vertical openings shall be enclosed with approved walls having a fire resistance rating of not less than one hour when such chimneys are located in a building less than 4 stories in height, and not less than 2 hours when such chimneys are located in a building 4 stories or more in height.
12. Do not fill the 2" space around the chimney with household insulation or any other material unless specified otherwise. Insulation placed in this area could prevent proper air circulation around the chimney and may cause adjacent combustible materials to overheat.
13. Self-tapping stainless screws are not required, but may be used to reinforce the connection and avoid accidental unlocking of chimney lengths. Use only 1/2" self-tapping screws. Do not penetrate the inner wall of the chimney.
14. When penetrating an exterior wall or ceiling/roof assembly, the vapor barrier must be repaired. This is easily accomplished by attaching the vapor barrier to the outer perimeter of any wall thimble, Firestop, or ceiling support component using approved sealant or tape, while also maintaining the minimum clearances-to-combustibles to the chimney's outer wall. When penetrating the building envelope, the gap between the outer layer of chimney and any Firestop or wall thimble can be sealed using high-temperature rated (600°F) silicone caulking. Should you require further clarification, consult your local authority having jurisdiction.
15. The safe operation of a factory-built chimney assembly is based on the use of parts supplied by the manufacturer and the performance of the assembly may be affected if the combination of these parts is not used in actual building construction. Acceptance of the assembly is void if the installation instructions are not followed.
16. Provisions must be made to ensure that all interior portions of the chimney be accessible for inspection and cleaning.

 **WARNING**

The clearance between the chimney and combustible material must not be less than 2", except where established by the support. Do not fill this area with insulation unless directed otherwise in these instructions.

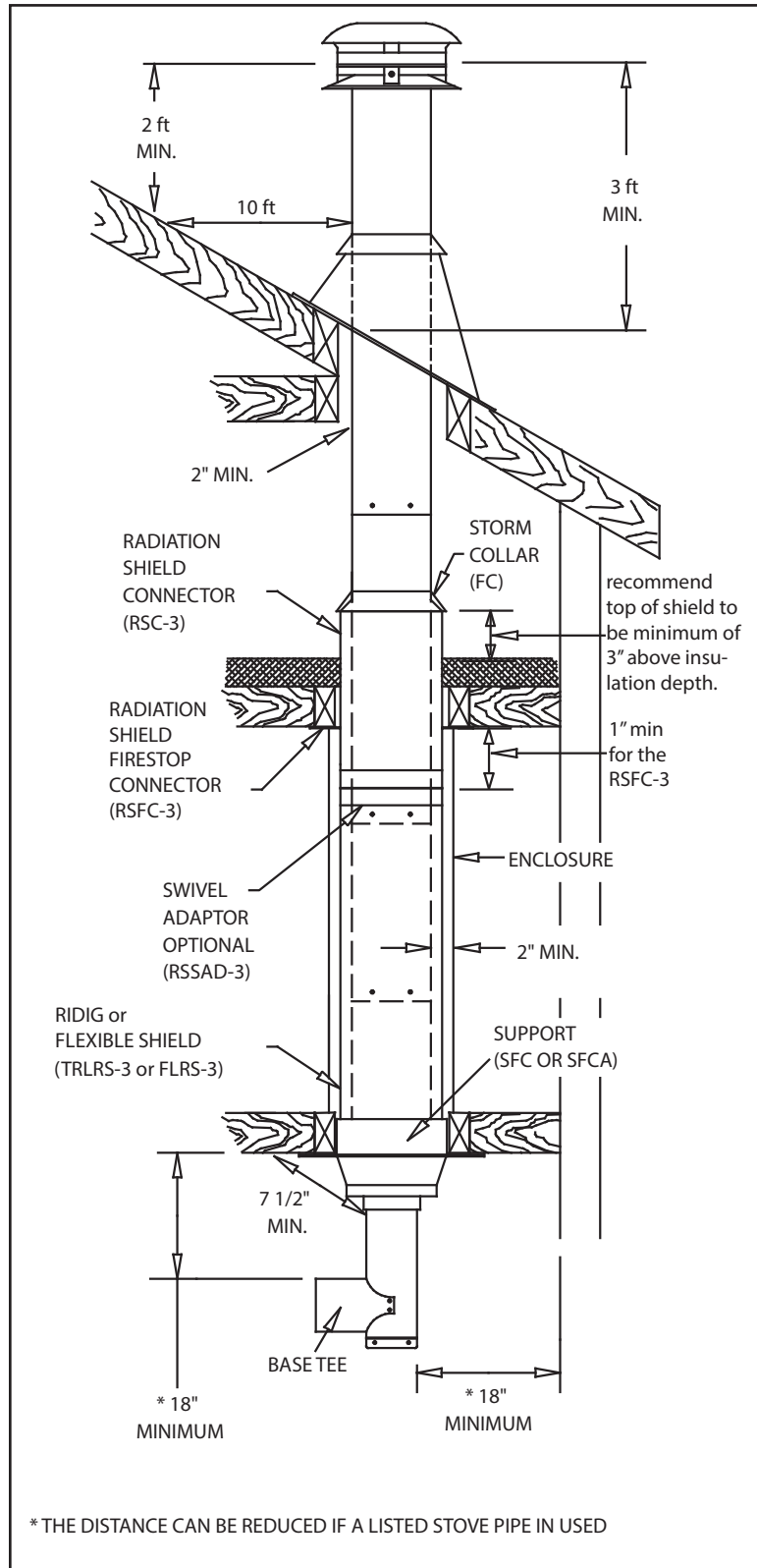

Figure 26

NOTE: DIAGRAMS & ILLUSTRATIONS ARE NOT TO SCALE.

8

INTERIOR STRAIGHT INSTALLATION - SINGLE FLOOR - CANADA

REDUCED CLEARANCE SUPPORT (RCS)

When using the Reduced Clearance Support (RCS) at the attic level, the use of the attic radiation shield is not required. The Reduced Clearance Support (RCS) acts as an attic radiation shield when installed with insulation and a collar (provided) (see **figure 27**).

NOTE: A Finishing Support (SFC) combined with an Attic Radiation Shield (ARSA) can also be used for this application. **Refer to SECTION 9: FINISHING SUPPORT (SFC)** for installation guide.

Step 1: Locate the chimney in a convenient place as near as possible to the appliance outlet.

Step 2: Cut and frame the opening in the ceiling and roof where the chimney will pass.

NOTE: It is important to follow the framing dimensions for floor openings as prescribed in **Table 9**.

Step 3: From below, push the Reduced Clearance Support into the framed opening in the ceiling. Ensuring the support is level, attach the support to the framed opening using (12) - 3" spiral nails or #8 x 1 1/2" wood screws (see Figure 3). At least 3 1/2" of the support must extend into the room. Screw the Finish Trim (included) to the ceiling.

NOTE: At least 3 1/2" of the support must extend down below the finished ceiling. This ensures minimum clearances are maintained to stovepipe. Fix the Finish Trim around the support using supplied screws.

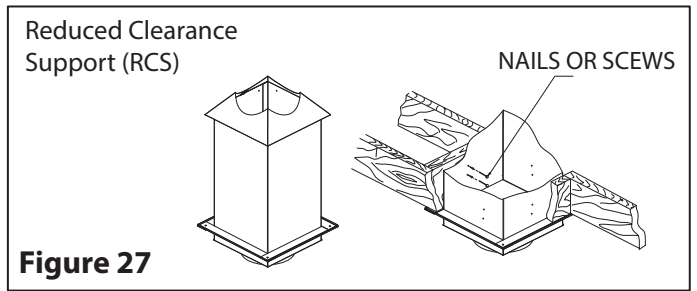

Figure 27

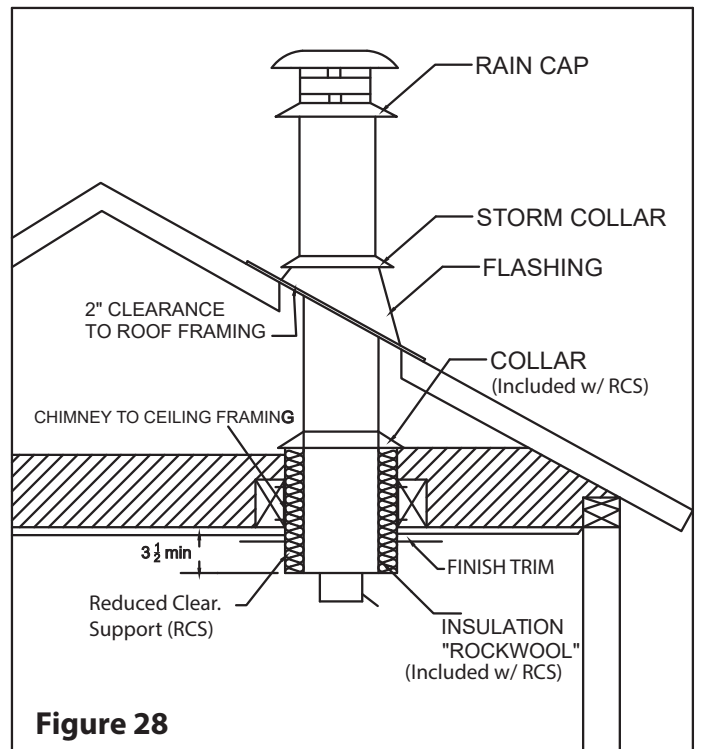

Figure 28

CHIMNEY SIZE	FRAMING DIMENSION	
	Reduce Clearance Support	ROOF
6"	10-1/8" x 10-1/8"	12-3/8" x 12-3/8"
7"	11-1/8" x 11-1/8"	13-3/8" x 13-3/8"
8"	12-1/8" x 12-1/8"	14-3/8" x 14-3/8"

Table 9

Step 4: Place first chimney length into the support. Twist to lock into place. Wrap the insulation pad around the chimney section. Slide insulation pad into the space between the chimney section and support making sure the insulation makes contact with the bottom of the support. Additional pieces of insulation can be loosely tucked down within corners. Do not compress insulation. This reduces effectiveness.

NOTE: If needed a Support Extension (SE) can be attached to the support to increase its height. **See SECTION 10: REDUCED CLEARANCE SUPPORT EXTENSION (SE).**

NOTE: Make sure arrow on pipe label is pointing upward.

Step 5: The square-to-round collar (included) features a fixing tab and slot.

To install, wrap the collar around the chimney.

Slide it down on top of the RCS Support.

Pull the sides of the collar together while inserting the collar's tab through the slot.

Once tight, fold the tab over to secure the collar. Check fit to ensure the collar completely covers the top of the support.

Step 6: Stack the next chimney length on the first length. Be sure that the male and female threads are not in line when putting the lengths together. Turn the chimney clockwise to lock it in place. Continue until the required chimney height is reached.

Step 7: **ROOF FLASHING INSTALLATION**

Put the roof flashing in place. Seal the joint between the roof and the flashing with roofing compound.

For sloping roofs, place the flashing under the upper shingles and on top of the lower shingles. Nail the flashing to the roof using nails. Place the storm collar around the chimney and slide down on top of the flashing.

Step 8: Tighten the collar using the supplied bolt. Make sure the joint is properly caulked (**see Figure 29**).

Step 9: Attach the rain cap to the top of the chimney.

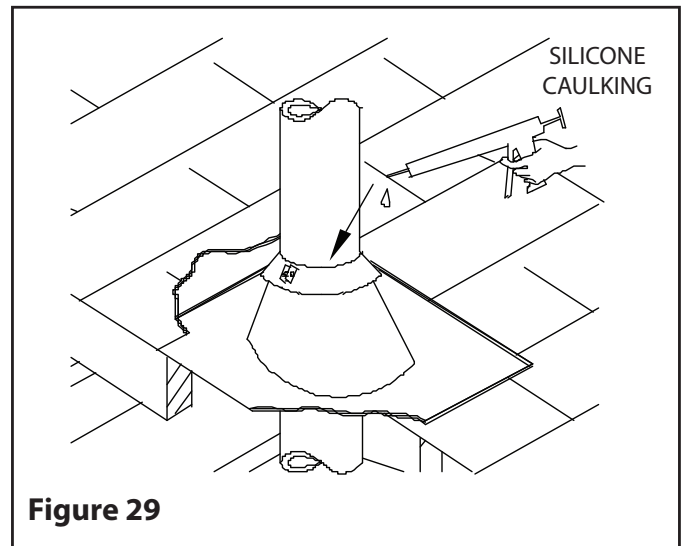

Figure 29

9

INTERIOR STRAIGHT INSTALLATION - MULTIPLE FLOOR - CANADA

if using the reduced clearance support (RCS), refer to table 9 for dimensions. When used for this application, the square-to-round collar is not used. When using the rcs, installer must always consider obstacles above that could encroach on or compromise clearances: truss top chord and diagonal webs etc. Clearance reduction only applies to portion of chimney protected by the support and the support extension.

FOR ENCLOSED INSTALLATION ON WOOD OR COAL BURNING APPLIANCE (6", 7", 8" dia.), only Finishing Support (SFC) can be used.

FINISHING SUPPORT (SFC)

Step 1. Locate the chimney in a convenient place as near as possible to the appliance outlet.

Step 2. Cut and frame the openings in the floor, ceiling and roof where the chimney will pass.

NOTE: It is important to follow the framing dimensions for the floor openings prescribed in this manual.

CHIMNEY SIZE	HOLE SIZE	
	FINISH SUPPORT (SFC)	RADIATION SHIELD FIRESTOP CONNECTOR (RSFC-3) & ROOF*
5"	12-1/8" x 12-1/8"	11-3/8" x 11-3/8"
6"	12-1/8" x 12-1/8"	12-3/8" x 12-3/8"
7"	14-3/8" x 14-3/8"	13-3/8" x 13-3/8"
8"	14-3/8" x 14-3/8"	14-3/8" x 14-3/8"
10"	---	16-3/8" x 16-3/8"

Table 10
* For sloping roofs, see Table 2

Step 3. From below push the finish support into the framed opening. Nail or screw the support to the framed box using (12) 3" spiral nails or #8 x 1 1/2" wood screws (see Figure 30).

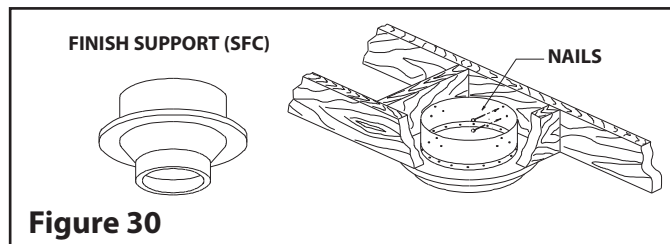
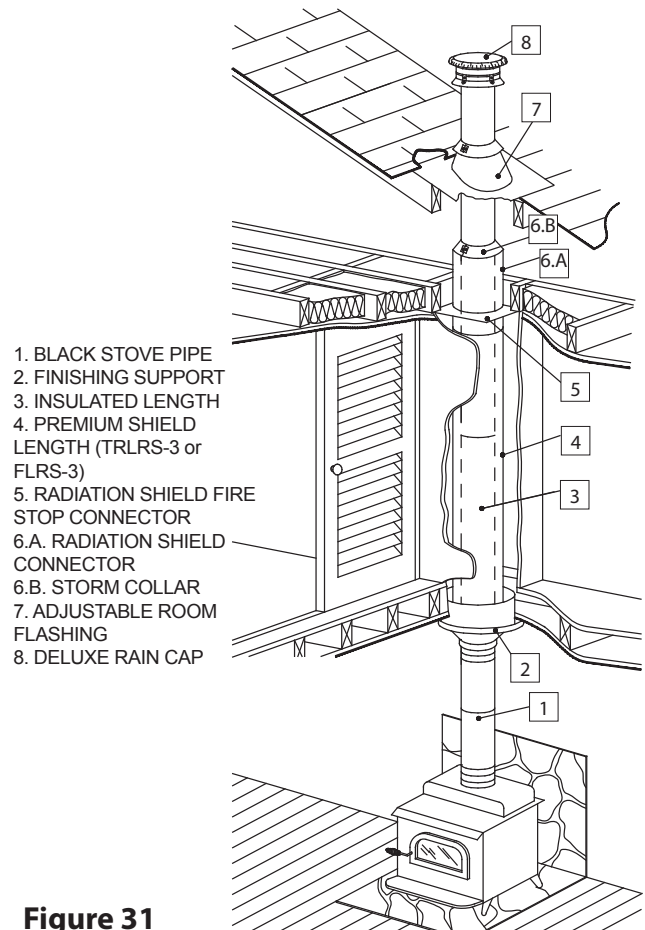

Figure 30

Step 4. If you are venting a Factory built fireplace or an oil or gas burning appliance please refer to installation notes #1 (on Section-7) for guidelines on the use of the Premium shields.

Step 5A. **FOR UNENCLOSED OR VENTING OF OIL OR GAS APPLIANCES:** Refer to interior installation on a furnace and water heater guideline (on Section-13).

Step 5B. **FOR ENCLOSED INSTALLATION ON WOOD OR COAL BURNING APPLIANCE (6", 7", 8" dia. only),** proceed according to the steps below and see Figure 31



1. BLACK STOVE PIPE
2. FINISHING SUPPORT
3. INSULATED LENGTH
4. PREMIUM SHIELD LENGTH (TRLRS-3 or FLRS-3)
5. RADIATION SHIELD FIRE STOP CONNECTOR
- 6.A. RADIATION SHIELD CONNECTOR
- 6.B. STORM COLLAR
7. ADJUSTABLE ROOM FLASHING
8. DELUXE RAIN CAP

Figure 31

Step 6. Lock the first chimney length into the support with the arrow on label pointing up.

Step 7. Slide a Telescopic Rigid shield (TRLRS-3) on top of that length all the way to the bottom. Stack the next chimney length on the first length. Be sure that the male and female threads are not in line when putting the lengths together. Turn the chimney clockwise to lock it in place. You may add a 1/2" stainless steel self tapping screw to prevent accidental unlocking. Continue installing until the chimney reached the ceiling.

Step 8. At the ceiling level, install a Radiation Shield Connector (RSC-3) and a Radiation Shield Firestop (RSFC-3) on the chimney (see Figure 32). Slide the Radiation Shield Connector down until the bottom of the insulated tube passes just through the Radiation Shield Firestop as shown in (see **Figure 32.A**). Adjust the height until a minimum of (1") of the Radiation Shield Connector passes through the firestop below. Fix it to the chimney from the attic side using (3) - 1/2" self-tapping screws. The Telescopic Shield is then slid upwards to the ceiling and attached to the bottom of the Radiation Shield Connector using (3) - 1/2" self-tapping screws.

Note: add one stainless steel self tapping screws provided, between each telescopic section, to reinforce telescopic joints.

Step 9. A Storm Collar (included with RSC-3) must be installed on top of the Radiation Shield Connector (RSC-3) to prevent any loose insulation from falling in the area between the chimney and the support (**See Figure 32.B**)

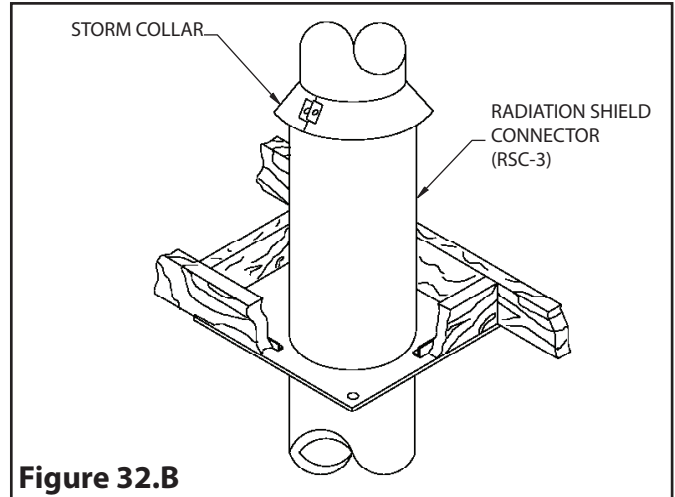
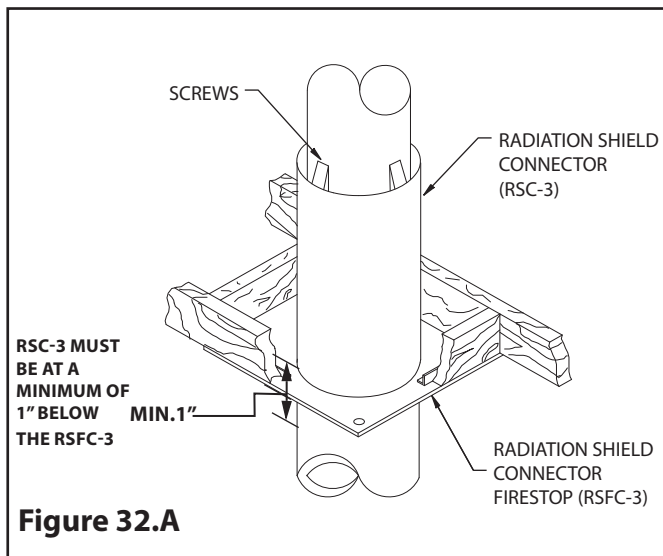

Step 10. **ROOF FLASHING INSTALLATION**

Put the roof flashing in place. Seal the joint between the roof and the flashing with roofing compound.

For sloping roofs, place the flashing under the upper shingles and on top of the lower shingles. Nail the flashing to the roof using roofing nails.

Place the storm collar over the chimney and the flashing. Tighten it with the bolt supplied making sure the joint is properly caulked (see **Figure 33**).

Step 11. Attach the rain cap to the top of the chimney.

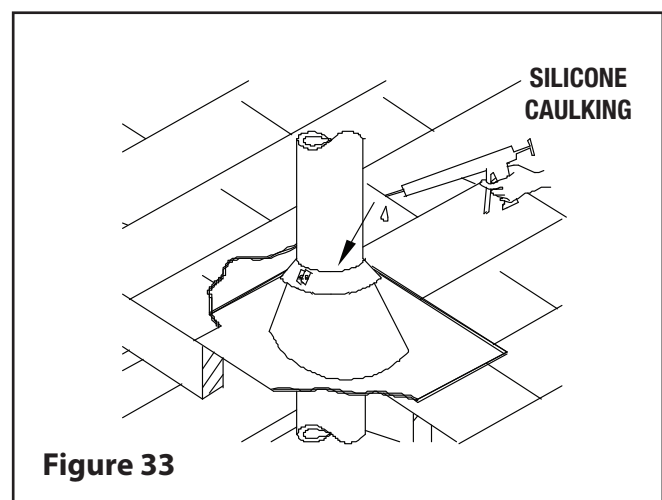

REDUCED CLEARANCE SUPPORT (RCS)

NOTE: The Reduced Clearance Support (RCS) comes with a collar. It can be discarded for a Cathedral Ceiling application, it is not required.

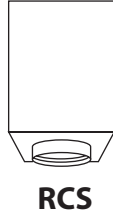

Step 1: Locate the chimney in a convenient location as near as possible to the appliance outlet. Cut and frame an opening in the roof for the support (see **Table 5**). The sides of this hole must be vertical (see **Figure 35**).

Step 2: From above, place the support in the opening.

NOTE: The bottom portion of the support must project below the ceiling. Distance will vary according to pitch (see **Table 12**). The minimum horizontal distance between single wall stove pipe and adjacent wall surfaces is 18".

Step 3: Use a level to ensure the support is vertical. If the support extends above the roof, cut it flush with the top of the roof. Attach the support to the framed opening using (12)-3" spiral nails or #8 x 1 1/2" wood screws (see **Figure 34**).

Step 4: Place first chimney length into the support. Twist to lock into place. Wrap the insulation pad around the chimney section removing any excess. Slide insulation pad into the space between the chimney section and support making sure the insulation makes contact with the bottom of the support. Additional pieces of insulation can be loosely tucked down within corners. Do not compress insulation. This reduces effectiveness.

Where desired, an extension (SE) is available for the support. This may be needed in steeper cathedral applications. Approved insulation can be used within the extension. It must be listed/compliant with ASTM E136/ULC S114 as non-combustible, have a melting temperature above 2000°F/1100°C, and be water resistant with low moisture absorption. Materials such as rockwool or mineral wool qualify.

TO CONTINUE INSTALLATION REFER TO SECTION 12: ROOF SUPPORT (ST)

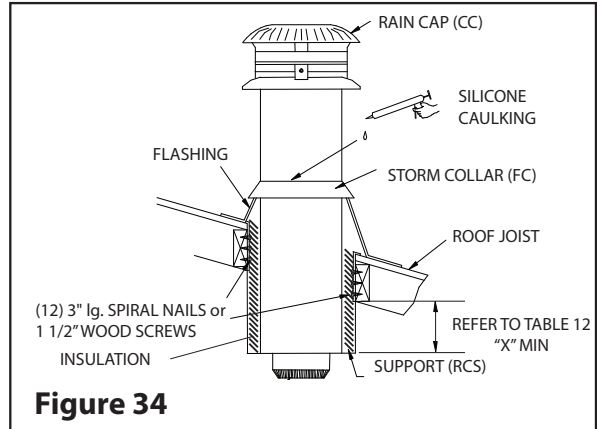

Figure 34

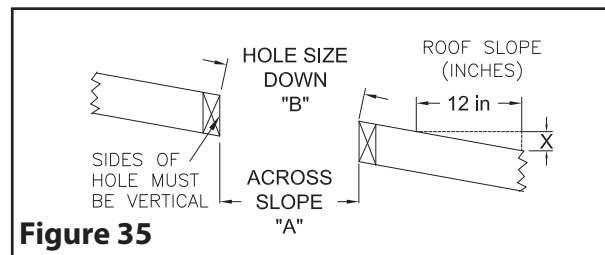

Figure 35

Chimney Size	6"		7"		8"	
Roof Slope (X/12)	Frame opening. (Reduce Clearance Support)					
	A	B	A	B	A	B
0	10-1/8	10-1/8	11-1/8	11-1/8	12-1/8	12-1/8
2/12	10-1/8	10-1/4	11-1/8	11-1/4	12-1/8	12-1/4
4/12	10-1/8	10-5/8	11-1/8	11-3/4	12-1/8	12-3/4
6/12	10-1/8	11-1/4	11-1/8	12-1/2	12-1/8	13-1/2
8/12	10-1/8	12-1/8	11-1/8	13-1/4	12-1/8	14-1/2
10/12	10-1/8	13-1/4	11-1/8	14-1/2	12-1/8	15-7/8
12/12	10-1/8	14-1/4	11-1/8	15-3/4	12-1/8	17-1/8

Table 11

NOTE: ALL DIMENSIONS ARE IN INCHES.

Reduce Clearance Support Extension (SE)

Steep pitched cathedral ceilings may require the use of a Support Extension (SE). This piece fits down inside the reduced clearance support and can be adjusted to increase the support's length by up to 22".

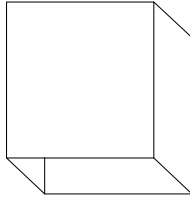

SE

The extension is attached to the support using the eight metal screws provided. Be sure there is at least a 2" overlap where the extension joins the support.

NOTE: Refer to Step 4 (**Section 4: RCS**) regarding additional insulation required with this extension.

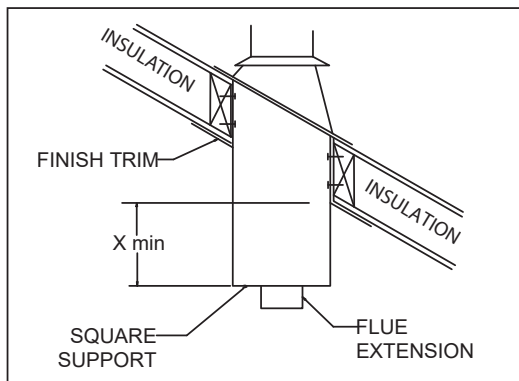

Figure 36

Slope	X min
0/12 - 2/12	3 1/2"
2/12 - 7/12	5 1/2"
7/12 - 12/12	6 3/4"
12/12 - 24/12	7 1/2"
24/12	12 1/2"

Table 12

SQUARE SUPPORT (SSC24)

This support is similar in application and installation as the Reduced Clearance Support. Install it using the instruction on Section 10: **REDUCED CLEARANCE SUPPORT (RCS)**. (Refer to **Figure 37** for visual references).

Approved insulation can be used within the square support and extension surrounding the chimney. It must be listed/compliant with ASTM E136/ULC S114 as non-combustible, have a melting temperature above 2000°F/1100°C, and be water resistant with low moisture absorption. Materials such as rockwool qualify.



SSC24

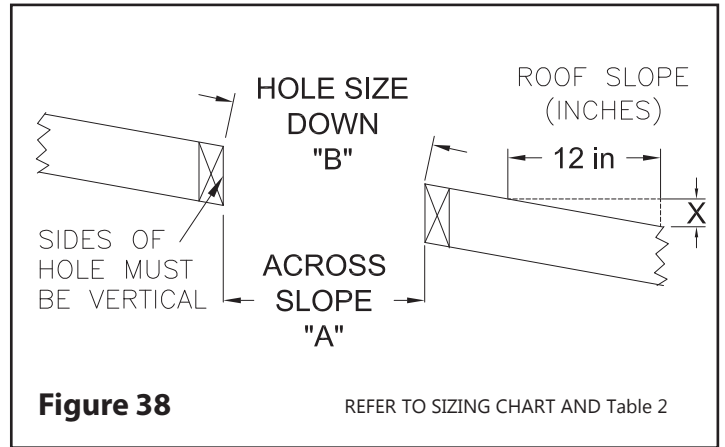

SUPPORT EXTENSION (PS24) (For Square Support only)

Steep pitched cathedral ceilings may require the use of a Square Support extension (PS24). This piece fits down inside the square support and can be adjusted to increase the support's length by up to 22"

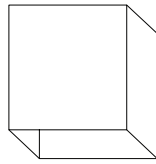

PS24

The extension is attached to the support using the eight metal screws provided. Be sure there is at least a 2" overlap where the extension joins the support.

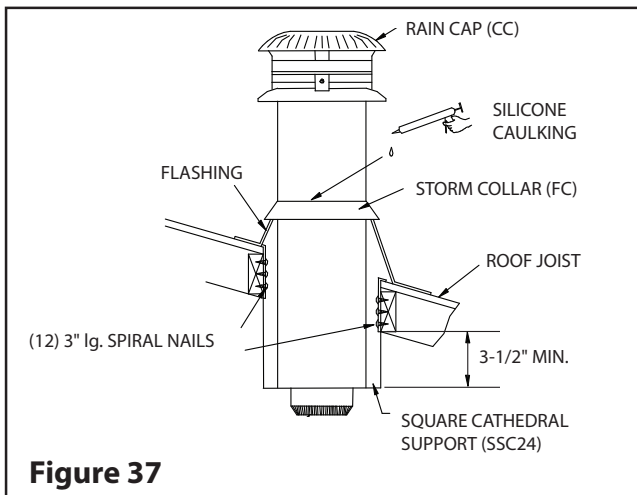

11 OFFSET DEVIATION - CANADA

OFFSET CHIMNEY

It may be necessary to offset the chimney to clear an obstruction such as a joist or truss, or to position the chimney close to the ridge cap. A maximum of two offsets (4 elbows in all) is allowed in a chimney. The chimney must not be inclined more than 45° from vertical **in Canada**.

The minimum chimney height when using 15° offsets is 10'.

The minimum chimney height when using 30° or 45° offsets is 15'.

The maximum length of unsupported offset chimney is 6'. If the offset chimney is longer than 6', then it must be supported at 6' intervals using a Wall Support (SO-2) or a Roof Support (ST). (See **Figure 39**)

⚠ WARNING

A support must always be installed right above each offset (two elbows) to support the chimney above the offset.

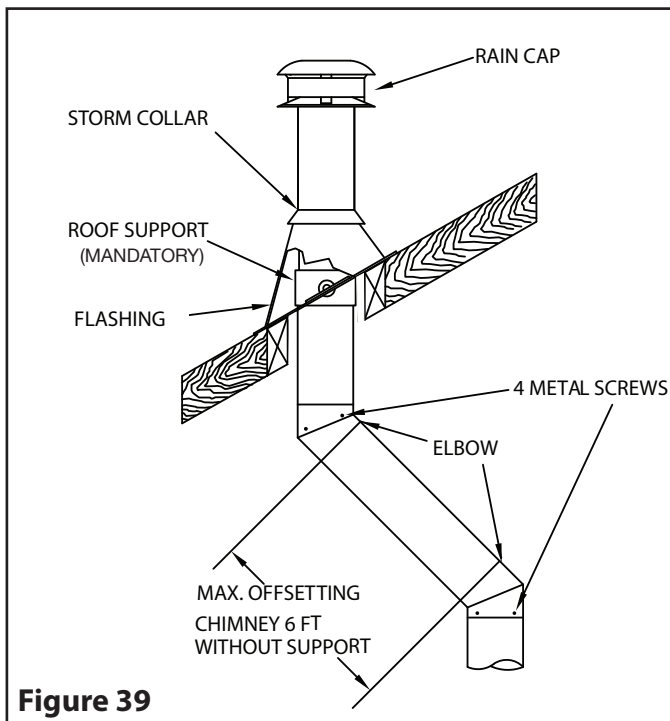

Figure 39

INSTALLATION INSTRUCTIONS

If you are venting a Factory built fireplace or an oil or gas burning appliance please refer to installation notes #1, (b. and .c, on **Section 7**) for guidelines on the use of the Premium shields.

For Interior Enclosed installation only (Wood or Coal burning appliance (6", 7", and 8" dia. only)). (See **Figure 40)**

Step 1. Place the first chimney length on a flat surface with the male coupling on top.

NOTE: If using a length shorter than 36" in the bottom support, you must first attach the elbow to this shorter section. Before proceeding to the next step, perform a test fit in the support to determine the required orientation of the elbow once attached to the Length. Then fasten it to the chimney using the (4) 1/2" metal screws provided.

Step 2. Slide a Flexible Shield (FLRS-3) on top of that length (or Length-Elbow combo) all the way to the bottom.

Step 3. Attach the flexible shield to the section using 3 x 1/2" stainless steel self tapping screws.

Step 4. Slide this assembly in the support and turn clockwise to lock it in place.

Step 5. At the ceiling level from below, position a Radiation Shield Connector Firestop (RSFC-3) (**See **Figure 41A****)

Step 6. At the ceiling level from the top, position a Radiation Shield Connector (RSC-3) and a Radiation Shield Support (RSSC-3) attached but not tightened together (see **Figure 41A**).

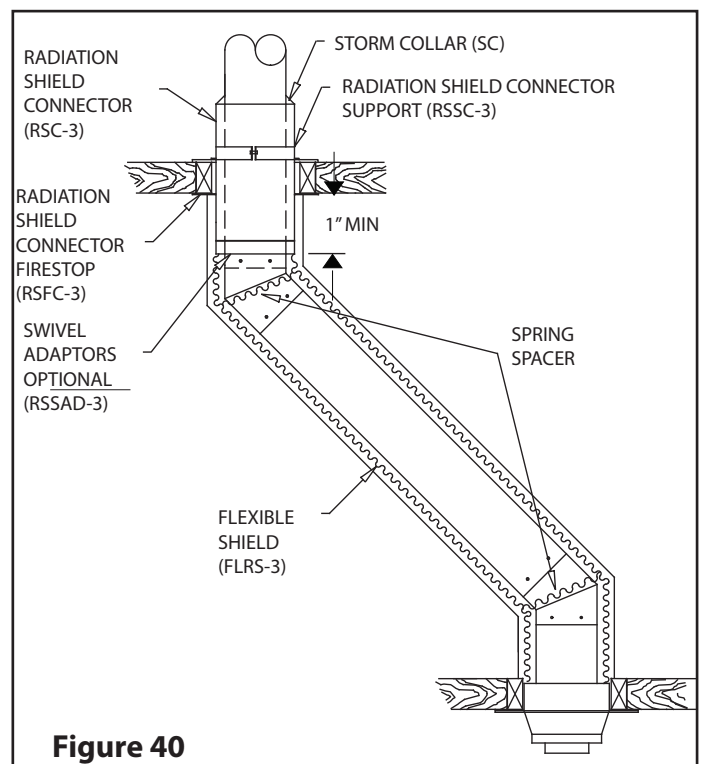

Figure 40

NOTE: DIAGRAMS & ILLUSTRATIONS ARE NOT TO SCALE.

11

OFFSET DEVIATION - CANADA (CONT'D)

Step 7. Slide the Radiation Shield Connector down until the bottom of the insulated tube exceed the bottom of ceiling. Adjust the height until a minimum of (1") of the Radiation Shield Connector project below the ceiling and tighten the support collar around the shield connector (see **Figure 40**).

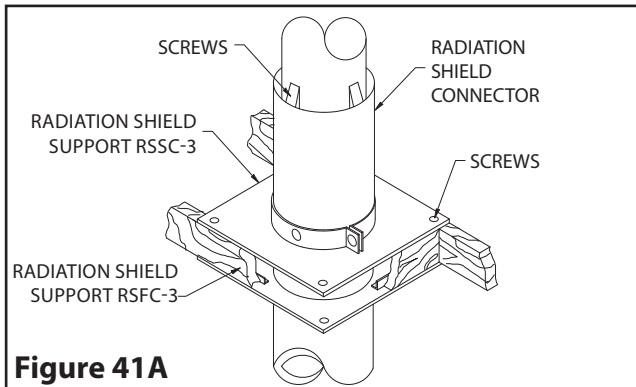

Figure 41A

NOTE: If the first elbow was already installed in Step 1, proceed to Step 9.

Step 8. Stack the next chimney length on the first length. Be sure that the male and female threads are not in line when putting the lengths together. Turn the chimney clockwise to lock it in place. You may add a 1/2 in stainless steel self tapping screw to prevent accidental unlocking. When you reach the height at which the elbow will be installed:

Step 9. Install the insulated offset elbow on the vertical chimney length. Turn it in the required direction and fasten it to the chimney with the (4)-1/2" metal screws provided.

Step 10. Place the required offset chimney length (see **Table 13**) on the elbow. Turn it clockwise to lock it in place.

Step 11. Use another elbow to turn the chimney vertically. Again secure the elbow to the chimney length using the (4)-1/2" metal screws.

- Attach a spacer spring around the chimney at each elbow to help keep the Flexible Shield centered. (See **Figure 40**)

Step 12. Slide the Flexible Shield up the chimney and attach it below the ceiling to the Radiation Shield Connector using (3) - 1/2" self tapping metal screws.

NOTE: If additional shield length is needed, two or more flex shields can be connected, or by using an additional Swivel Adaptor (RSSAD-3) between both Flexible Shield (FLRS-3).

NOTE: If you are limited in space to be able to fix the screws that fix the FLEX (FLRS-3) to the Radiation Shield Connector, (RSC-3) install a Swivel Adaptor (RSSAD-3) (see **Figure 40**) below the Shield Connector (RSC-3) and one on the top end of the Flexible Shield.

Step 13. From the attic, feed the subsequent pipe Lengths through the Radiation Shield Connector (RSC-3) down to the top elbow. Rotate each length clockwise to secure on the Elbow.

Step 14. Fix the Radiation Shield Connector (RSC-3) to the chimney.

Step 15. A Storm Collar (Included with RSC-3) must be installed on top the of Radiation Shield Connector (RSC-3) to prevent any loose insulation from falling in the area between the chimney and the support. (See **Figure 41.B**)

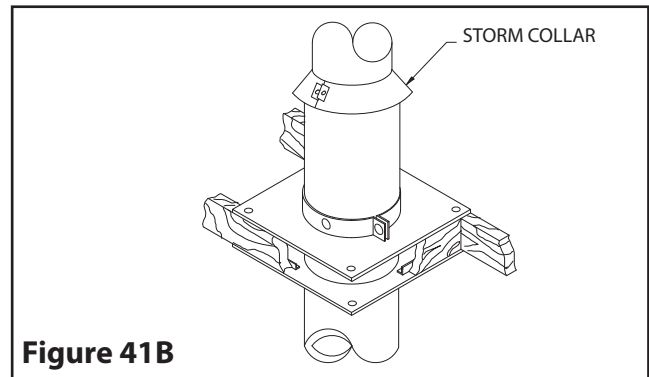

Figure 41B

For Unenclosed installation or venting of oil or gas appliances:

Step 1. Put the first chimney length in the support. Turn it clockwise to lock it in place. Stack the next chimney length on the first length. Be sure that the male and female threads are not in line when putting the lengths together. Turn the chimney clockwise to lock it in place. You may add a 1/2" stainless steel self tapping screw to prevent accidental unlocking. When you reach the height at which the elbow will be install:

Step 2. Install the insulated offset elbow on the vertical chimney length. Turn it in the required direction and fasten it to the chimney with the (4)-1/2" metal screws provided.

Step 3. Place the required offset chimney length (see **Table 13**) on the elbow. Turn it clockwise to lock it in place.

11

OFFSET DEVIATION - CANADA (CONT'D)

Step 4. Use another elbow to turn the chimney vertically. Secure the elbow to the chimney length using the (4)-1/2" metal screws provided. Install the remaining chimney as described in the instructions for the Interior Straight installation **on Section 9**.

Step 5. Install the remaining chimney as described in the instructions for the Roof Support (**See section 12**).

INSTALLATION CALCULATIONS

Determine the offset required in view of the obstacles that must be avoided (see **Figure 42**). Refer to **Table 13** to determine the elbows required as well as the insulated length needed. If required, an adjustable length can be used to offset exact distance required.

OFFSET & RISE CHART MODEL ASHT (5" - 10")

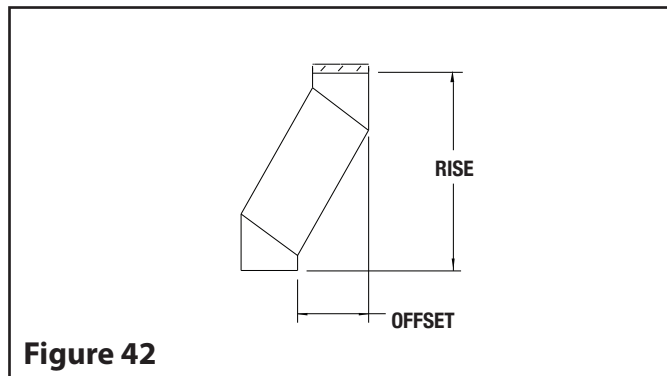

OFFSET & RISE CHART MODEL DTC (5", 6", 7", 8", 10")

ANGLE	DIA.	INCHES	ONE LENGTH BETWEEN ELBOWS					
			8	12	18	24	36	48
15°	5", 6", 7", 8", 10"	Offset	3-5/16	4-5/16	5-7/8	7-7/16	10-1/2	13-5/8
		Rise	15-11/16	19-9/16	25-3/8	31-3/16	42-3/4	54-3/8
30°	5", 6", 7", 8", 10"	Offset	7-7/16	9-7/16	12-7/16	15-7/16	21-7/16	27-7/16
		Rise	20	23-1/2	28-11/16	33-7/8	44-1/4	54-11/16
45° (Canada Only)	5", 6", 7", 8", 10"	Offset	10-5/16	13-3/16	17-3/8	21-5/8	30-1/8	38-5/8
		Rise	17-13/16	20-5/8	24-7/8	29-1/8	37-5/8	46-1/8

ANGLE	DIA.	INCHES	TWO LENGTHS BETWEEN ELBOWS					
			8 & 48	12 & 48	18 & 48	24 & 48	36 & 48	48 & 48
15°	5", 6", 7", 8", 10"	Offset	15-3/8	16-7/16	18	19-1/2	22-5/8	25-3/4
		Rise	60-15/16	64-13/16	70-9/16	76-3/8	87	99-9/16
30°	5", 6", 7", 8", 10"	Offset	30-13/16	32-13/16	35-13/16	38-13/16	44-13/16	50-13/16
		Rise	60-9/16	64	69-1/4	74-7/16	84-13/16	95-1/4
45° (Canada Only)	5", 6", 7", 8", 10"	Offset	43-7/16	46-1/4	50-1/2	54-3/4	63-1/4	71-11/16
		Rise	50-15/16	53-3/4	58	62-1/4	70-3/4	79-3/16

Note: All dimensions are in inches.

Table 13

ROOF SUPPORT (ST)

The Roof Support has three possible uses:

It may be used to support a chimney from the roof. It adjusts to any roof pitch.

It may be used on a floor, ceiling or roof above an offset to support the chimney above the offset.

It may be used on a floor, ceiling or roof as a supplementary support when the chimney height exceeds that of the primary support. (See maximum length height supported, **Table 1**).

CAUTION: MAKESHIFT INSTALLATION ON ROOF ASSEMBLIES CAN CAUSE A HAZARDOUS ENVIRONMENT.

INSTALLATION INSTRUCTIONS

With the chimney extending through the opening in the roof, ceiling or floor proceed as follows (Refer to **Figure 44** for visual references):

- Step 1. Assemble the Roof Support's Collar to fit your chimney diameter. Continue to assemble the support as described in the instructions supplied with the support.
- Step 2. Slip the assembled Roof Support down over the stainless steel chimney until its brackets rest on the roof or floor. Tighten the collar around the chimney, (see **Figure 43**).
- Step 3. Center the chimney and nail or screw the support to the roof or floor using (8) - 2-1/2" nails or (8) №. 8 - 1-1/4" wood screws. (**Figure 43**).
- Step 4. Install the remaining chimney lengths, until the required chimney height is reached.

ATTENTION! Do not block the space between the flashing and the chimney. It is required to be fully open for the purpose of ventilation.

Step 5. ROOF FLASHING INSTALLATION

Put the roof flashing in place. Seal the joint between the roof and the flashing with roofing compound.

For sloping roofs, place the flashing under the upper shingles and on top of the lower shingles. Nail the flashing to the roof using nails. Place the storm collar around the chimney and slide down on top of the flashing. Tighten it with the bolt supplied making sure the joint is properly caulked (see **Figure 33**)

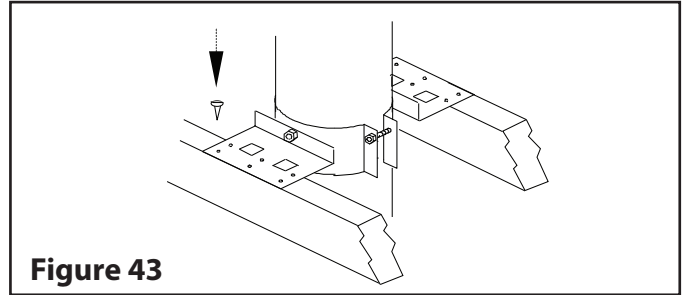
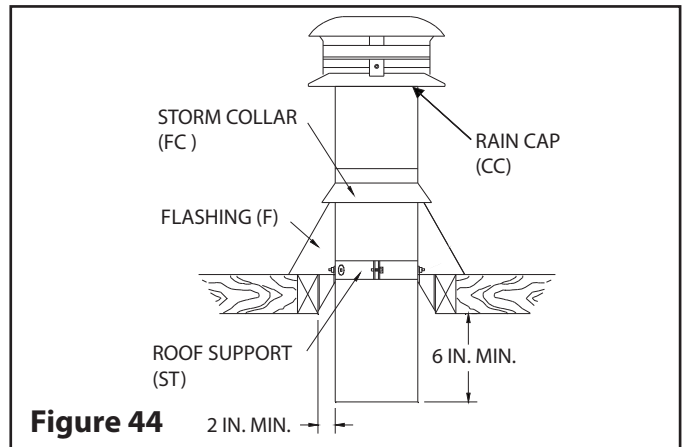
**Figure 43****Figure 44**

Step 6. For Cap installation, also refer to section CAP REMOVAL FOR MAINTENANCE.

EXTERIOR INSTALLATION INFORMATION

This chimney will provide optimum performance when installed within the heated space of a building. The consequences of installing the chimney outdoors, up the exterior wall of a building could result in:

- Back-drafting during cold weather when the connected appliance is not operating.
- Weak, unstable draft.
- Increased creosote accumulation
- Increased potential for condensation of water vapor in the chimney flue decreased efficiency of the connected appliance.

If you do install an exterior chimney, we recommend that you enclose it using an insulated enclosure.

EXTERIOR INSTALLATION NOTES

1. Premium Shield are not approved for exterior installation. If the chimney is to be enclosed in a chase, maintaining at least 3" to combustible allow the chimney to be enclosed without the need of the Premium Shield accessories. The Wall Support and Wall Straps will need to be adjusted to 3" clearance from vertical exterior wall.
2. If the chimney is to be unenclosed, maintain a minimum of 2" clearance to combustible materials.
3. A Wall Strap or WALL SUPPORT must be used to secure the chimney to the wall when used on an unenclosed exterior wall. Maximum distance between wall bands is 8'.
4. The horizontal chimney length passing through the wall must project a minimum of 5" and no more than 24" beyond the inside wall. Minimum projection is required to ensure appropriate clearances are maintained once stovepipe is installed.
5. If an exterior installation is to be enclosed, allow for access to base of tee to facilitate required cleaning.
 - The minimum distance between the bottom of the Tee or Support and any horizontal combustible is always 2" by using an insulated tee cap (TCI).

WALL SUPPORT

When a chimney is used along a wall, this support may be used to support the chimney. The height of chimney supported is shown in supported height See **Table 1**.

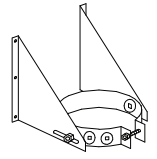
**SO-2****INSTALLATION INSTRUCTIONS**

Install the support as follows (see **Figure 45**):

- Step 1. Assemble the collar to fit your chimney diameter. Continue to assemble the support as described in the instructions supplied with the support.
- Step 2. Slip the support down over the chimney to the proper location.
- Step 3. Tighten the collar around the chimney.
- Step 4. Attach the support brackets to the wall using (8) 3" nails or (8) N^o. 10 x 1-1/4" wood screws.

NOTE: Be sure that the support attaches to a framing and not merely to dry wall or siding.

Step 5. Continue installing the chimney.

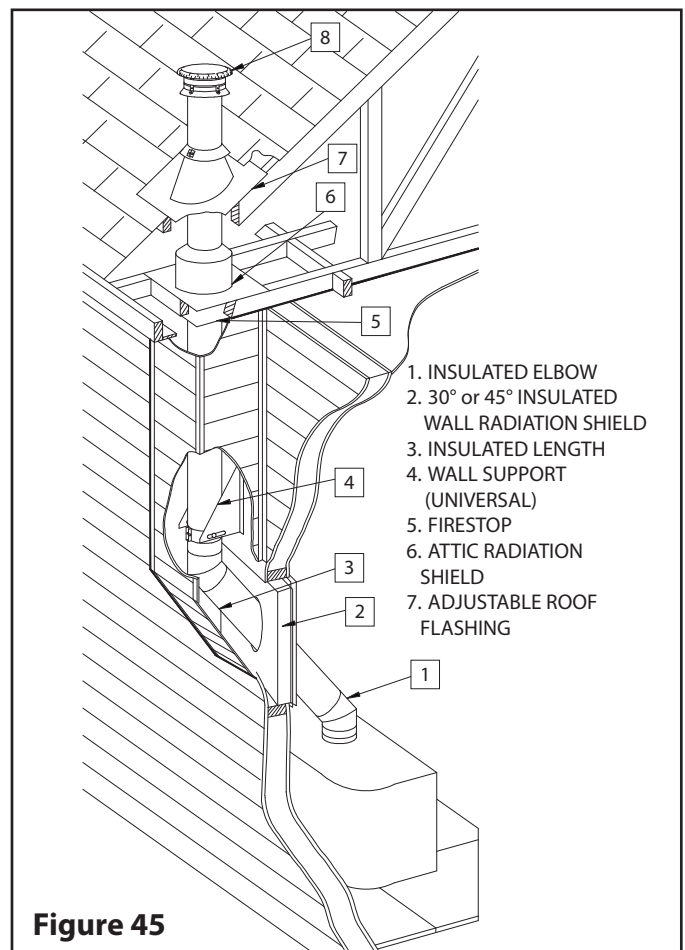
**Figure 45**

NOTE: DIAGRAMS & ILLUSTRATIONS ARE NOT TO SCALE.

WALL SUPPORT

See different types of Wall Support on **Figure 46**.

INSTALLATION INSTRUCTIONS

Step 1. Determine where the chimney will pass through the wall.

- For concrete walls cut an opening as per Table 14 below.
- For combustible walls cut and frame a hole as per Table 14 below, midway between the wall studs (see **Table 14**).

Normally wall studs are placed at 16" on center with the hole midway between them, the support will fasten to these studs and thus ensure a strong attachment to the wall (see **Figure 47**).

Step 2. Wood walls: Place the exterior half of the Wall Thimble (RSM-2) in the opening from the outside. Nail in place using (4) 2" nails or 1" screws. This Wall Thimble is adjustable from 7" to 12" (see **Figure 48**). Make sure the insulation pad is cut to the desired length according to the wall thickness. Place the interior half of the Wall Thimble inside the exterior half of the Wall Thimble. For a wall requiring more than 12", a shield extension can be field fabricated using galvanized sheet metal 26 gauge minimum.

Ensure the opening for the chimney to pass through is straight and level. Screw the inner thimble in place with the provided screws (see **Figure 49**).

NOTE: The cavity surrounding the wall thimble metal shield can be filled with insulation (see **Figure 49**).

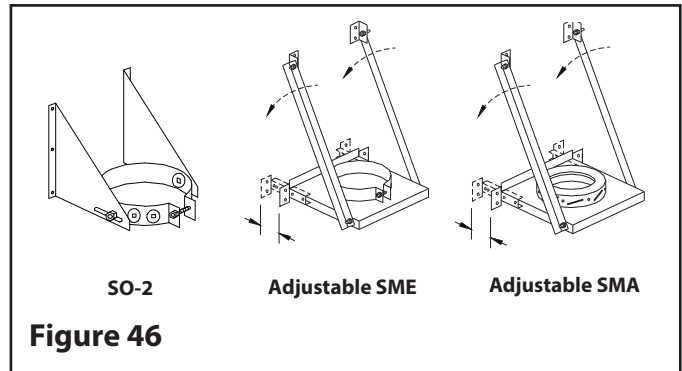

Figure 46

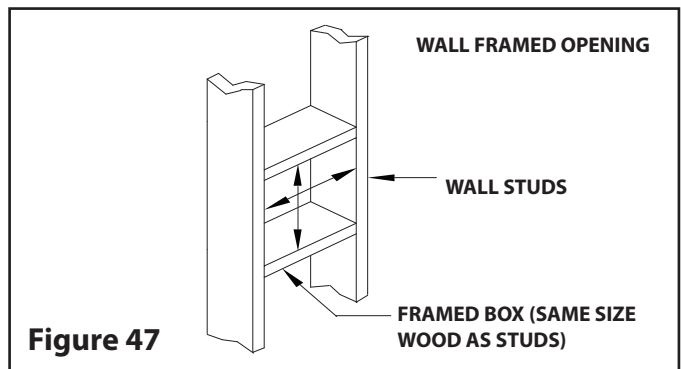

Figure 47

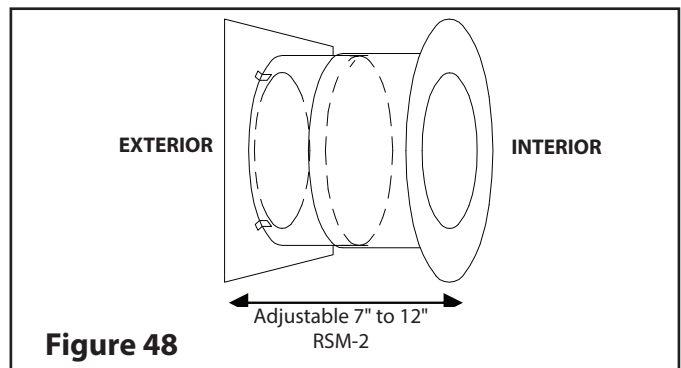

Figure 48

CHIMNEY SIZE	OPENING SIZE	
	COMBUSTIBLE	CONCRETE
5"	11" x 11"	7-3/4"
6"	12" x 12"	8-3/4"
7"	13-3/8" x 13-3/8"	9-3/4"
8"	14-3/8" x 14-3/8"	10-3/4"
10"	16-3/8" x 16-3/8"	12-3/4"

Table 14

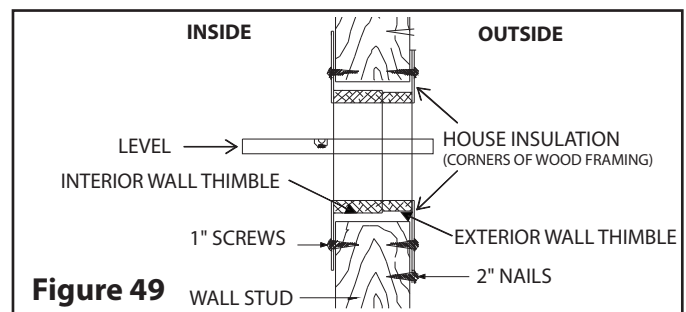
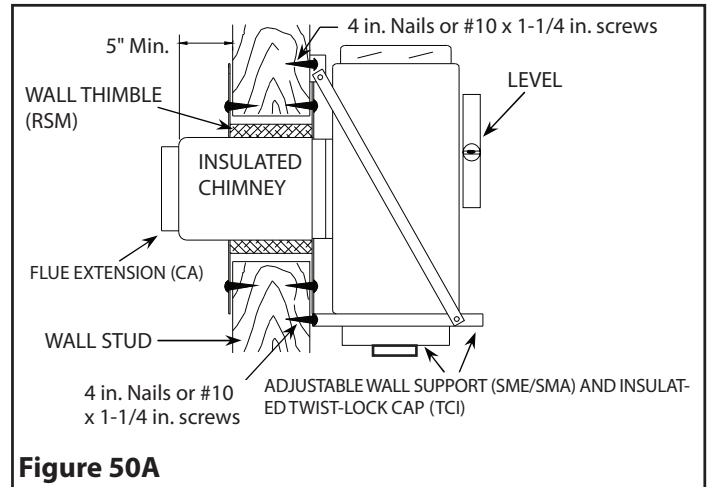
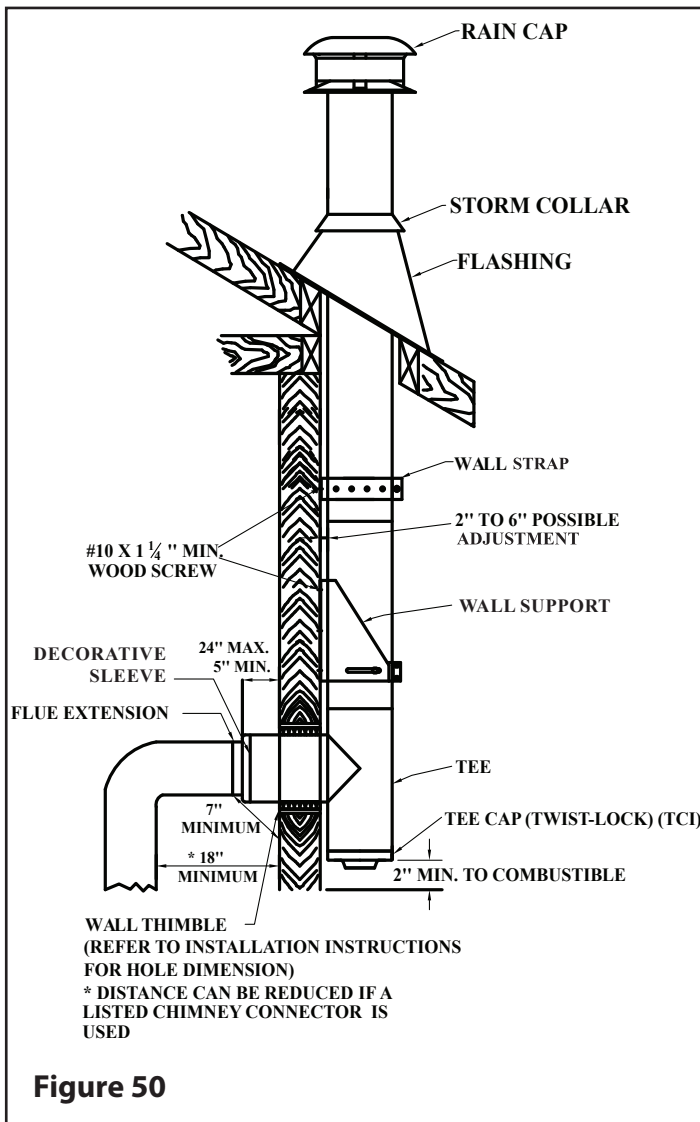

Figure 49

Step 3. The minimum length of insulated chimney required to pass through the wall will be thickness plus 7". The insulated chimney must extend at least 5" into the room beyond the finished wall. Insert this chimney length in the side branch of the insulated tee. Turn it clockwise to lock it in place. Seal this joint by wrapping it with the aluminum tape supplied with the tee. Mount the insulated tee on the support so that the chimney length which will go through the wall is perpendicular to the side of the support that will fasten to the wall.

NOTE: The supports (SO-2 or SME) can be installed above the Tee. (See **Figure 50**).

Step 4. This step will require 2 people: (see **Figure 50A**). Insert the chimney length of this tee-support assembly into the hole in the wall. Using a level, ensure the tee is vertical, then attach the support to the wall using (8) N^o. 10 x 1 - 1/4" wood screws or 4" spiral nails.



NOTE: To provide sufficient strength, the nails must be driven into the wall studs. For concrete walls, the support should be attached using (8) 1/4" x 2" lag bolts.

Step 5. Attach the clean-out cap to the Tee Support or Tee.

Step 6. Attach the flue extension to the horizontal chimney length.

Step 7. Stack a chimney length on top of the Tee. Turn it clockwise to lock it in place. Continue until the required chimney height is reached.

For unenclosed installation:

Step 8. At 8' intervals, attach the chimney to the wall using a Wall Strap or wall Support. If the chimney passes through the roof, cut a hole large enough to provide 2" clearance between the chimney and the roof. For pitch roof, See **roof opening chart on table 2 (SEE FIGURE 51)**

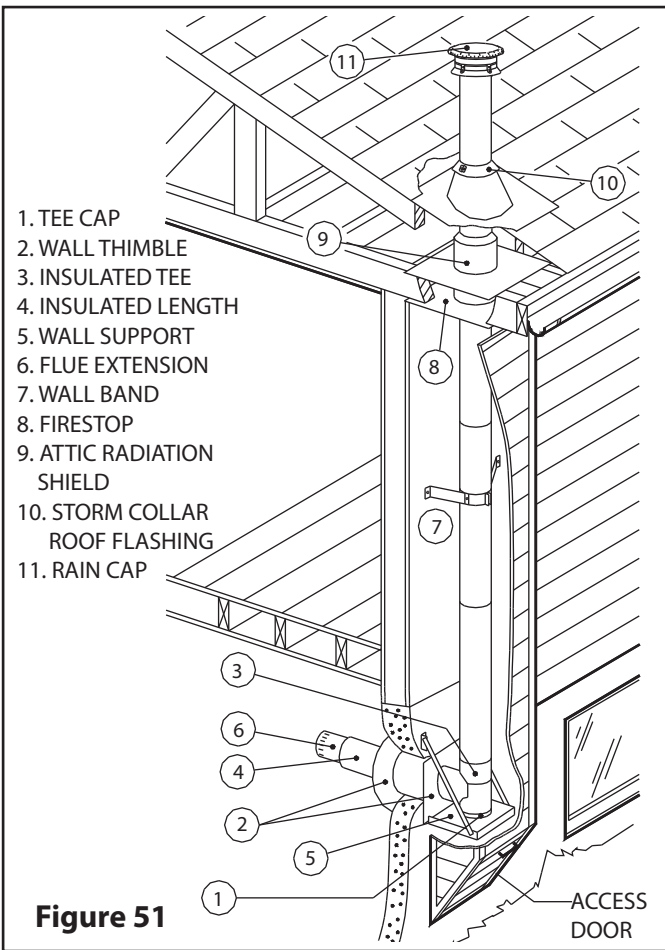

13

INTERIOR INSTALLATION ON A GAS FURNACE, BOILER, OR WATER HEATER (USA & CANADA)

Step 1. Locate the chimney in a convenient place as near as possible to the appliance outlet. Cut and frame the opening in the ceiling where the chimney will pass.

NOTE: It is important to follow the framing dimensions for the floor openings prescribed in this manual.

Refer to Table 1 for proper framing dimensions.

Step 2. From below push the support into the framed hole. Nail the support to the framed box using (12) 3" spiral nails or #8 x 1 1/2" wood screws (see **Figure 52**).

Step 3. Put this first chimney length in the support. Turn it clockwise to lock it in place.

NOTE: Arrow on pipe label must be pointing up.

Step 4. From below, install a Firestop (BF) in each floor through which the chimney passes (see **Figure 53**).

Step 5. Stack the next chimney length on the first length. Be sure that the male and female threads are not in line when putting the lengths together. Turn the chimney clockwise to lock it in place. Continue until the required chimney height is reached.

Step 6. At the attic level, install a Firestop (BF), from below and an Attic Radiation Shield (ARSA) from above (see **Figure 54**).

Step 7. (USA ONLY) Install the roof radiation shields in the roof hole framing. These shields consist of four metal plates. Nail one plate to each side of the joist using (2) 2-1/2" nails.

Step 8. Put the roof flashing in place. Seal the joint between the roof and the flashing with roofing compound.

For sloping roofs, place the flashing under the upper shingles and on top of the lower shingles. Nail the flashing to the roof using roofing nails.

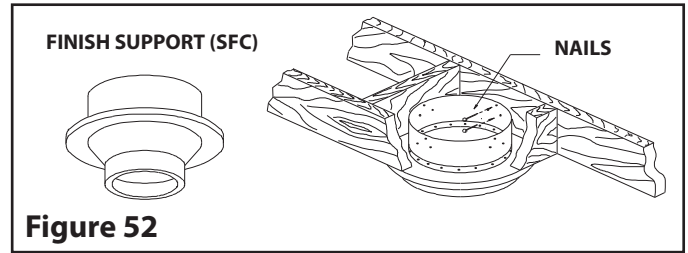

Figure 52

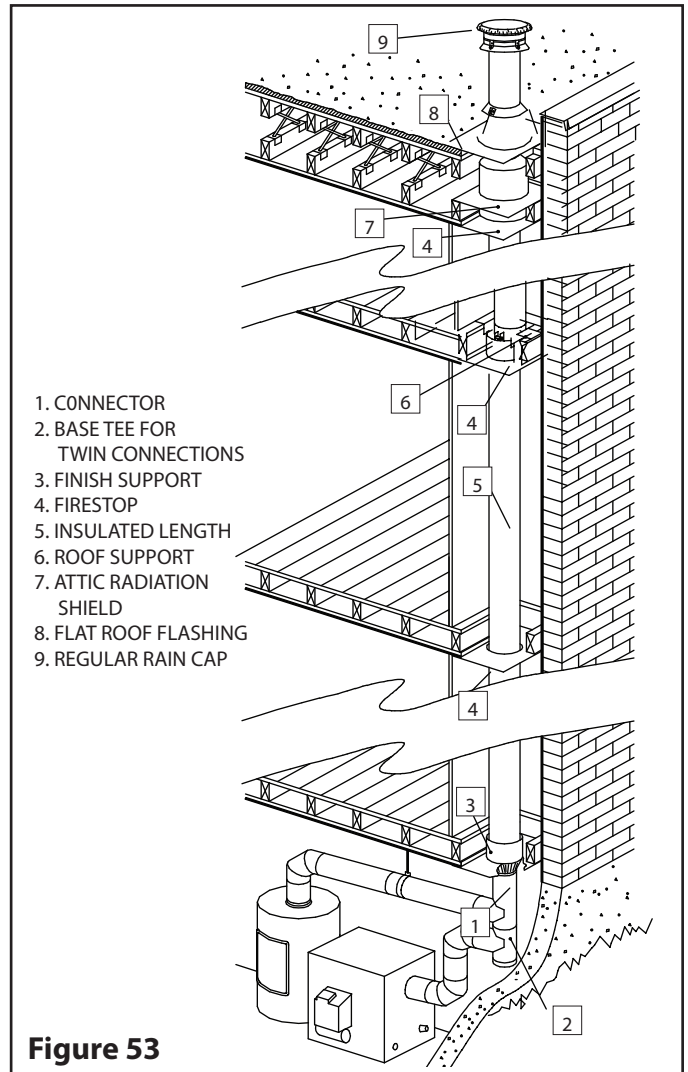

Figure 53

13

INTERIOR INSTALLATION ON A FURNACE, BOILER, OR WATER HEATER (USA & CANADA), (CONT'D)

Step 9. Place the storm collar over the chimney and the flashing. Tighten it with the bolt supplied making sure the joint is properly caulked (see **Figure 55**).

Step 10: Attach the rain cap to the top of the chimney.

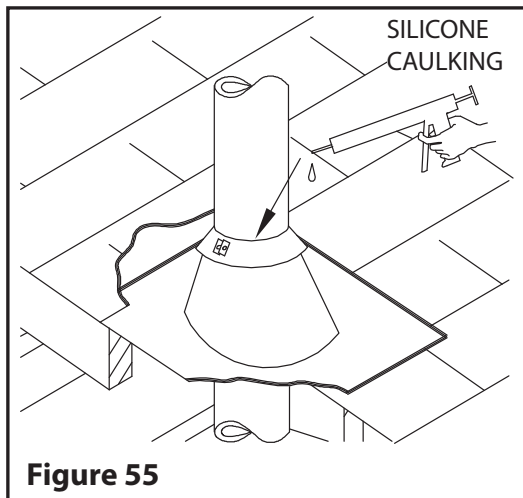
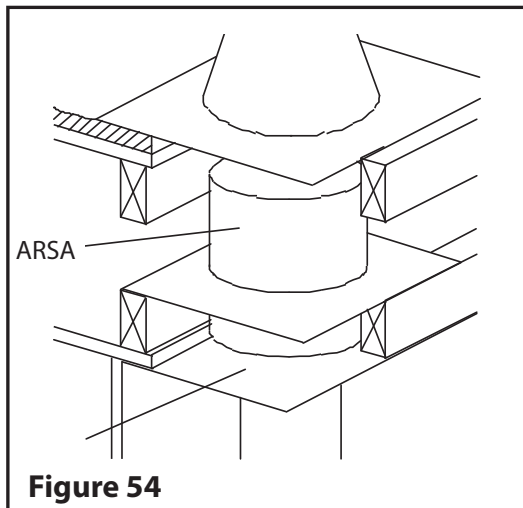

14

SPECIALIZED COMPONENTS (USA & CANADA)

ANCHOR PLATE (SP)

This support is used on a factory built fireplace or masonry fireplace of a furnace to provide a positive connection to the chimney. It is not to be used in contact with any combustible material, such as on a wood floor.

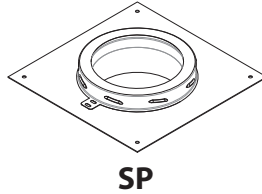

INSTALLATION INSTRUCTIONS

Once the appliance is installed, bolt the Anchor Plate (SP) to it (see **Figure 56**).

NOTE: To make sure that the coupler of the Anchor Plate is not spinning on it's axis, screw the tab at the position needed.

FACTORY-BUILT FIREPLACES

For chimneys installed on factory-built fireplaces, follow the installation instructions accompanying the fireplace.

INSULATED WALL RADIATION SHIELDS

These are used only with wood-burning fireplaces which have been certified for use with ASHT.

ANGLED INSULATED RADIATION SHIELD (RSMI30°/RSMI45°) It has been designed for use when a chimney passes through a wall at an angle (see **Figure 57**). Ref **Table 15**.

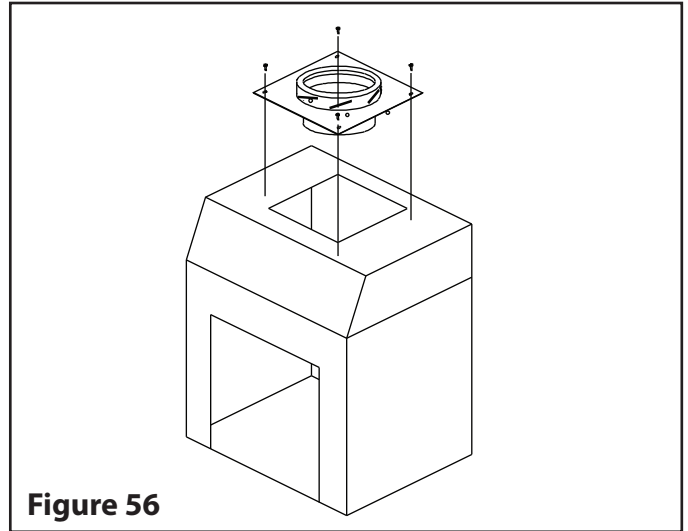

Figure 56

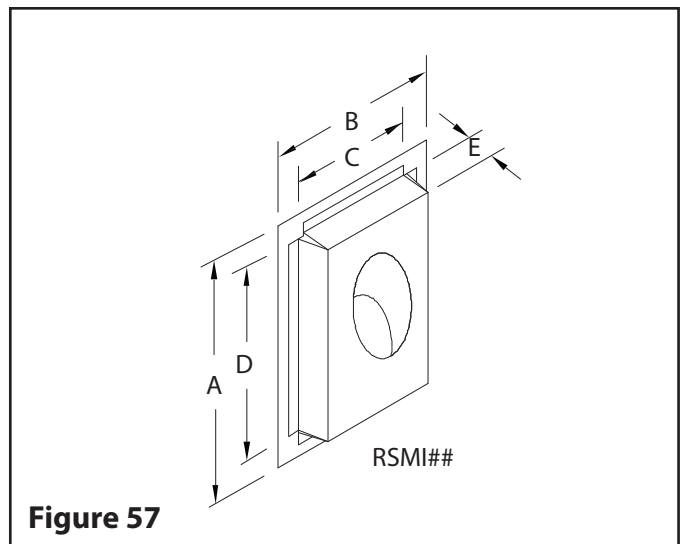

Figure 57

DIM.	SIZE					
	RSMI30			RSMI45 (CANADA ONLY)		
	7"	8"	10"	7"	8"	10"
A	37-3/4	39-3/4	45-5/16	26-5/8	28	30-1/2
B	16-5/8	17-5/8	19-3/8	16-5/8	17-5/8	19-3/8
C	12-5/8	13-5/8	15-3/8	12-1/8	13-1/2	14-7/8
D	33-3/4	35-3/4	39-1/4	22-1/8	23-1/2	26
E	3	3	3	3	3	3

Table 15

15

REPLACEMENT PARTS



LENGTHS & FITTINGS		
ØL8-3	ØGL8	LENGTH Ø" X 8"
ØL12-3	ØGL12	LENGTH Ø" X 12"
ØL18-3	ØGL18	LENGTH Ø" X 18"
ØL24-3	ØGL24	LENGTH Ø" X 24"
ØL36-3	ØGL36	LENGTH Ø" X 36"
ØL48-3	ØGL48	LENGTH Ø" X 48"
ØLA-3	ØGLA	ADJUSTABLE LENGTH, 12"
ØTI-3	ØGTI	TEE WITH TEE CAP (TWIST LOCK)
ØTCI		INSULATED TEE CAP (TWIST LOCK)
ØE15-3	ØGE15	INSULATED ELBOW 15 DEGREE
ØE30-3	ØGE30	INSULATED ELBOW 30 DEGREE
ØE45-3	ØGE45	INSULATED ELBOW 45 DEGREE
SUPPORTS		
ØSSC24		SQUARE CATHEDRAL SUPPORT 24"
PS24		SQUARE SUPPORT EXTENSION 24"
ØSFC		FINISHING SUPPORT W/COUPLER
ØSFCA		FINISHING SUPPORT W/COUPLER WITH REMOVABLE COLLAR
ØRCS		REDUCE CLEAR. SUPPORT INS. 24"
ØSE		SQUARE SUPPORT EXTENSION 24"
ØSMA-2		ADJUSTABLE TEE SUPPORT WITH COUPLING

15

REPLACEMENT PARTS



ØSME	ADJUSTABLE TEE SUPPORT WITH COLLAR
SO-2	WALL SUPPORT (UNIVERSAL)
ST, XST	ROOF SUPPORT
ØSD	FLOOR SUPPORT
ØSP	ANCHOR PLATE

BRACES & FIRESTOPS



ØBF	FIRESTOP
ØRSM30	ANGLED FIRESTOP - 30 DEGREE
ØRSM45	ANGLED FIRESTOP - 45 DEGREE
ØRS	RADIATION SHIELD
ØSRSE	PASS-THROUGH RAD. SHIELD (INSULATED CHIMNEY)
ØARSA	ADJUSTABLE INSULATED ATTIC RADIATION SHIELD
ØRSI	INSULATED RADIATION SHIELD
ØRSM-2	INSULATED WALL THIMBLE
ØCA	FLUE EXTENSION
ØRSMI30	INSULATED WALL RADIATION SHIELD - 30 DEGREE
ØRSMI45	INSULATED WALL THIMBLE - 45 DEGREE
BS2	UNIVERSAL ROOF BRACE
BM-2	UNIVERSAL WALL BAND
ØBH	GUY WIRE BAND (WIRE NOT INCLUDED)



VENTED FLASHING (STORM COLLAR INCLUDED)

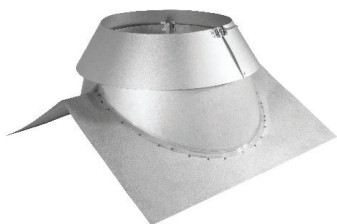

ØF	FLAT ROOF FLASHING
ØFA	ADJUSTABLE ROOF FLASHING 1/12 -7/12

15

REPLACEMENT PARTS

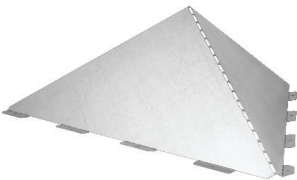

ØFB	ADJUSTABLE ROOF FLASHING 8/12 -12/12
ØFBB	ADJUSTABLE ROOF FLASHING 12/12 -21/12
ØFP	PEAK ROOF FLASHING 1/12 -7/12
ØFPB	PEAK ROOF FLASHING 8/12 -12/12
ØFAA	ADJUSTABLE ROOF FLASHING 1/12 TO 7/12, ALUMINUM MALLEABLE
ØFBA	ADJUSTABLE ROOF FLASHING 8/12 TO 12/12, ALUMINUM MALLEABLE
ØFC	STORM COLLAR
FSD	FLASHING SNOW DIVERTER
OTHERS	
ØCC	RAIN CAP
PE	UNIVERSAL SPARK ARRESTER BAND
ØPB	ASHT DECORATIVE COLLAR, SINGLE-WALL STOVE PIPE
ØDS	DECORATIVE SLEEVE
ØPF	DECORATIVE TRIM
ØTRLRS-3	TELESCOPIC RIGID LENGTH RADIATION SHIELD
ØFLRS-3	FLEXIBLE LENGTH RADIATION SHIELD
ØRSSC-3	RADIATION SHIELD SUPPORT CONNECTOR
ØRSFC-3	RADIATION SHIELD FIRESTOP CONNECTOR
ØRSC-3	RADIATION SHIELD CONNECTOR
ØRSSAD-3	RADIATION SHIELD SWIVEL ADAPTOR
INSTALLATION KITS	
ØWSK-2	WALL SUPPORT KIT (INCLUDES: 1 OF EACH ØTCI, ØRSM-2, ØT90, ØCA, ØDQDH, BM-2, SO-2, ØCC)
ØIKNC-2	INTERIOR KIT NEW CONSTRUCTION (INCLUDES: 1 OF EACH ØSFCA, ØARSA, ØCC)

To order a replacement part, please reach out to your nearest dealer, distributor, or to security.customer.service@duraventgroup.com

WARRANTY

This product has a limited lifetime warranty. Please read the warranty to be familiar with its coverage.

Retain this manual. File it with your other documents for future reference.

PRODUCT REFERENCE INFORMATION

Please contact Security Chimneys International for the phone number of your nearest Security Chimneys International dealer who will answer your questions or address your concerns.

Normally, all parts should be ordered through your Security Chimneys International distributor or dealer. Parts will be shipped at prevailing prices at time of order.

When ordering repair parts, always give the following information:

1. The model number of the vent system.
2. The part number.
3. The description of the part.
4. The quantity required.
5. The installation date of the chimney system.

If you encounter any problems or have any questions concerning the installation or application of this system, please contact your dealer.

SECURITY CHIMNEYS INTERNATIONAL LIMITED
2125 Monterey, Laval, Quebec, Canada, H7L 3T6
800-667-3387

Visit us at www.securitychimneys.com



2125 Monterey, Laval, Quebec, Canada, H7L 3T6
800-667-3387; www.securitychimneys.com

Security Chimneys International Limited reserves the right to make changes at any time, without notice, in design, materials, specifications, prices.
Consult your local distributor for chimney system code information.